

PR-100 PANFAB PROFILE

- MODEL PR-110 SQUARE RIBBING

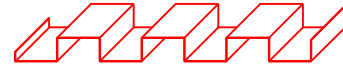

- MODEL PR-120 HORIZONTAL RECTANGULAR RIBBING



- MODEL PR-130 VERTICAL RECTANGULAR RIBBING



- MODEL PR-140 VARIABLE RECTANGULAR RIBBING

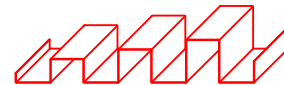

- MODEL PR-150 TRAPEZOID RIBBING



- MODEL PR-160 1 ANGLE RIBBING



- MODEL PR-170 2 ANGLES RIBBING



- MODEL PR-180 TRIANGULAR RIBBING



USE:

- Aluminium wall cladding (vertical or horizontal installation)

DESCRIPTION:

- Custom bent rib profile (63 different models)
- Custom width x length up to 13'-0" = 3962mm (min 6'-0" = 1829mm)
- Visible fasteners / screws at the bottom of the rib

FINISH OPTION:

- 0.8mm special alum. alloy 5754H42 with pre-painted "D-MAX" finish such as Duranar XL
- Choice of 7 standard inventory colors (White RAL9016, Jupiter RAL9006, Neptune, Alpha Centauri, Charcoal, Rigel-2 and Black RAL9005)
- Several exclusive finish options such as EuraBuild, EuraDesign, EuraMica, AluNatur (available on special orders of a minimum of 11 000 square feet with 0.8mm thickness)

LES INDUSTRIES



49, boul. de la Seigneurie Est
Blainville (Québec) J7C 4G6

Phone : (450) 430-3029

www.panfab.com

Project:

PR-100 PANFAB PROFILE

Title:

PRESENTATION OF MODELS

Scale:

1:10

Date:

JANUARY 2023

Page:

10000

ASSEMBLY - COMBINED PROFILE EFFECT (MIX AND MATCH)

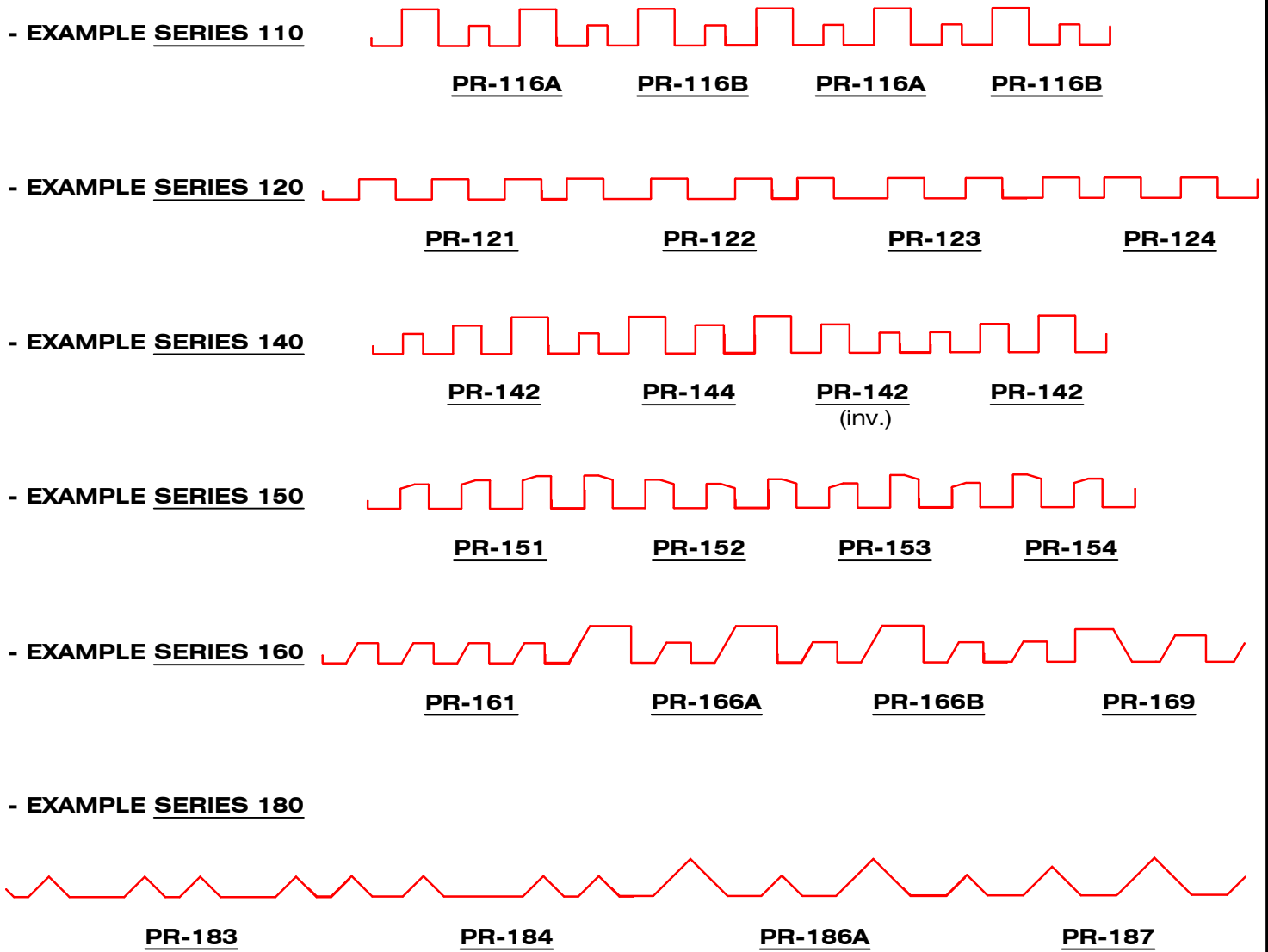

LES INDUSTRIES



49, boul. de la Seigneurie Est
Blainville (Québec) J7C 4G6

Phone : (450) 430-3029

www.panfab.com

Project:

PR-100 PANFAB PROFILE

Title:

ASSEMBLY - COMBINED PROFILE EFFECT

Scale:

1:10 / 1:4

Date:

JANUARY 2023

Page:

100010

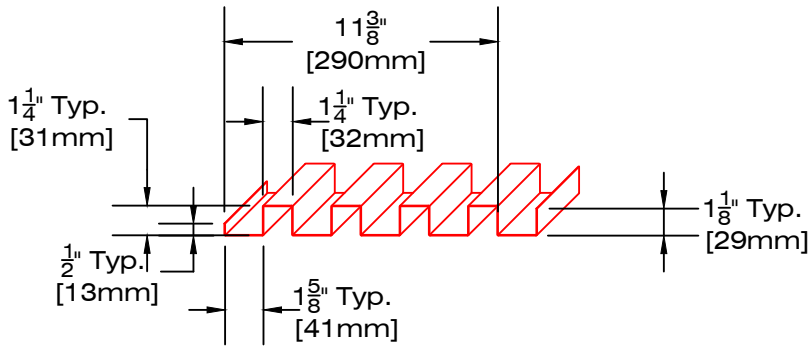

MODEL PR-111

4x A ribs 1 1/4" height
 Width 11.4" (46%)
 Blank 24 5/8" (x 2 = 49 1/4")

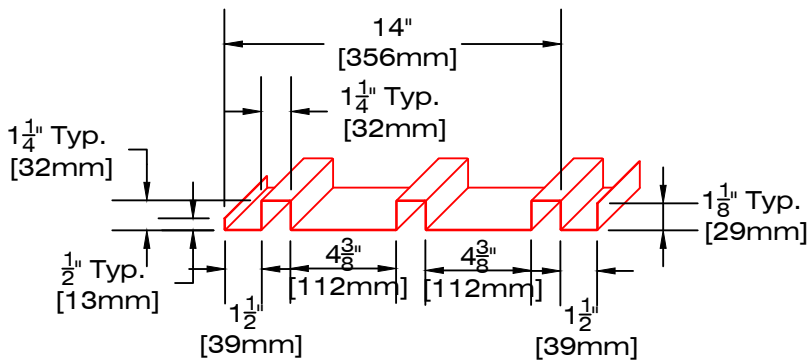

MODEL PR-112

3x A ribs 1 1/4" height
 Width 14" (57%)
 Blank 24 5/8" (x 2 = 49 1/4")

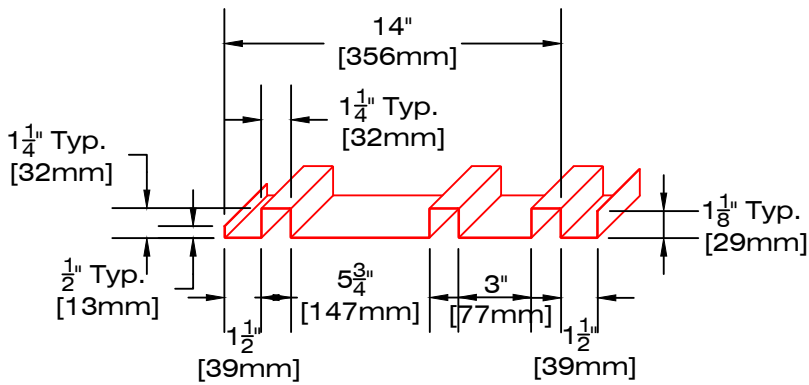

MODEL PR-113

3x A ribs 1 1/4" height
 Width 14" (57%)
 Blank 24 5/8" (x 2 = 49 1/4")

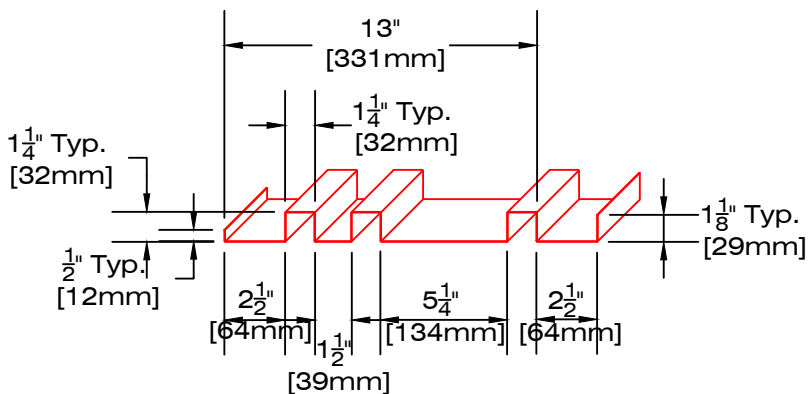

MODEL PR-114

3x A ribs 1 1/4" height
 Width 13" (53%)
 Blank 24 5/8" (x 2 = 49 1/4")

LES INDUSTRIES



49, boul. de la Seigneurie Est
 Blainville (Québec) J7C 4G6

Phone : (450) 430-3029

www.panfab.com

Project:

PR-100 PANFAB PROFILE

Title:

MODEL PR-110 SQUARE RIBBING

Scale:

1:8

Date:

JANUARY 2023

Page:

100110

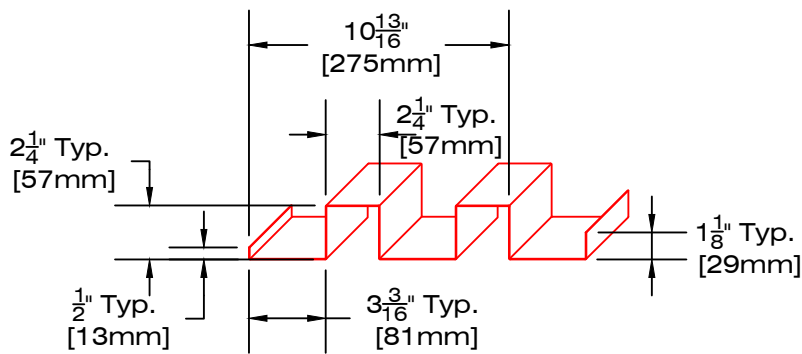

MODEL PR-115

2x B ribs $2\frac{1}{4}$ " height
 Width 10.834 " (44%)
 Blank $24\frac{5}{8}$ " (x 2 = $49\frac{1}{4}$ ")

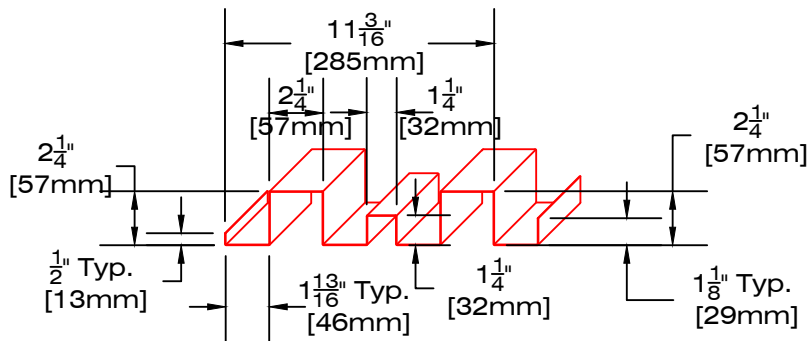

MODEL PR-116A

1x A rib $1\frac{1}{4}$ " height
 2x B ribs $2\frac{1}{4}$ " height
 Width $11\frac{3}{16}$ " (43%)
 Blank $26\frac{1}{8}$ " (+ $23\frac{1}{8}$ " = $49\frac{1}{4}$ ")

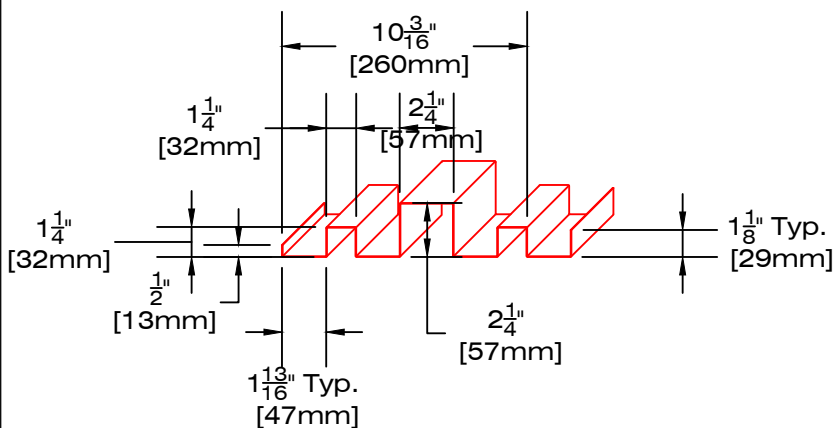

MODEL PR-116B

2x A ribs $1\frac{1}{4}$ " height
 2x B ribs $2\frac{1}{4}$ " height
 Width $10\frac{3}{16}$ " (44%)
 Blank $23\frac{1}{8}$ " (+ $26\frac{1}{8}$ " = $49\frac{1}{4}$ ")

LES INDUSTRIES



49, boul. de la Seigneurie Est
 Blainville (Québec) J7C 4G6

Phone : (450) 430-3029

www.panfab.com

Project:

PR-100 PANFAB PROFILE

Title:

MODEL PR-110 SQUARE RIBBING

Scale:

1:8

Date:

JANUARY 2023

Page:

100111

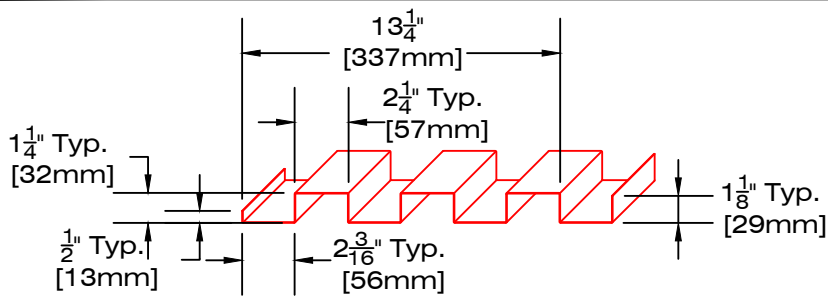

MODEL PR-121

3x A ribs 1 1/4" height
 Width 13 1/4" (54%)
 Blank 24 5/8" (x 2 = 49 1/4")

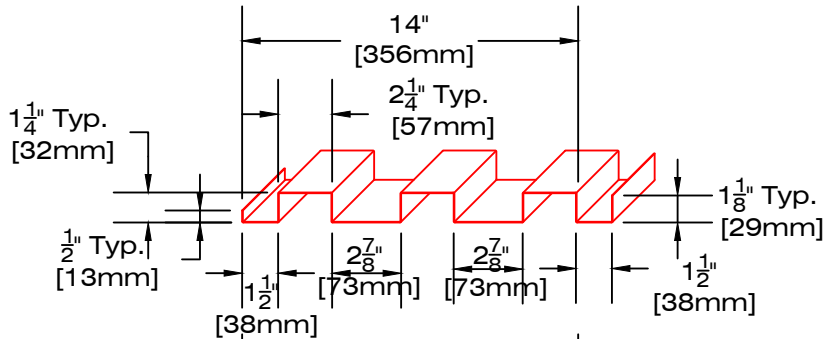

MODEL PR-122

3x A ribs 1 1/4" height
 Width 14" (57%)
 Blank 24 5/8" (x 2 = 49 1/4")

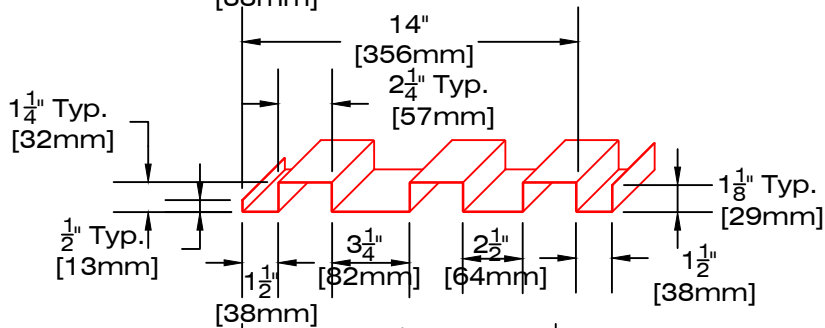

MODEL PR-123

3x A ribs 1 1/4" height
 Width 14" (57%)
 Blank 24 5/8" (x 2 = 49 1/4")

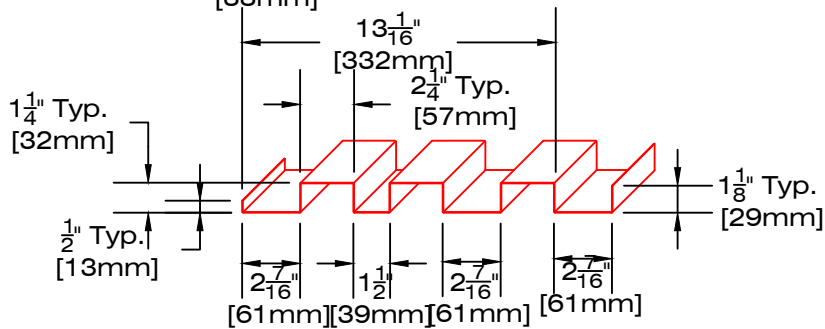

MODEL PR-124

3x A ribs 1 1/4" height
 Width 13.084" (53%)
 Blank 24 5/8" (x 2 = 49 1/4")

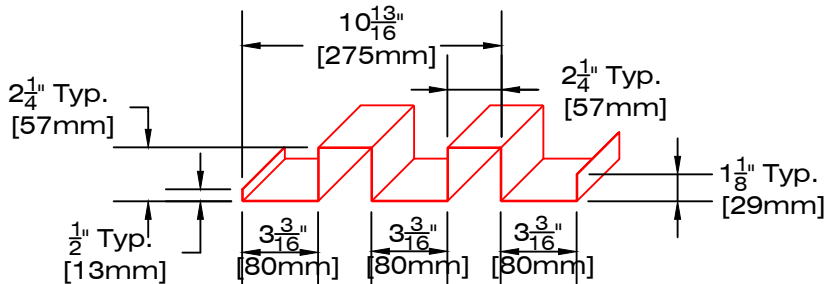

MODEL PR-125

2x B ribs 2 1/4" height
 Width 10.834" (44%)
 Blank 24 5/8" (x 2 = 49 1/4")

LES INDUSTRIES



49, boul. de la Seigneurie Est
 Blainville (Québec) J7C 4G6

Phone : (450) 430-3029

www.panfab.com

Project:

PR-100 PANFAB PROFILE

Title:

PR-120 HORIZONTAL RECTANGULAR RIBBING

Scale:

1:8

Page:

100120

Date:

JANUARY 2023

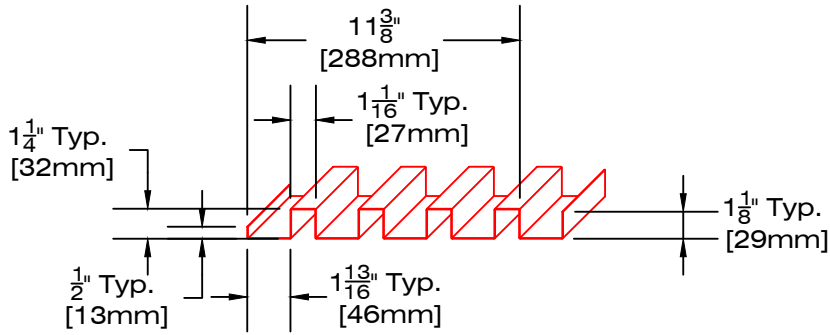

MODEL PR-131

4x A ribs 1 1/4" height
 Width 11 3/8" (46%)
 Blank 24 5/8" (x 2 = 49 1/4")

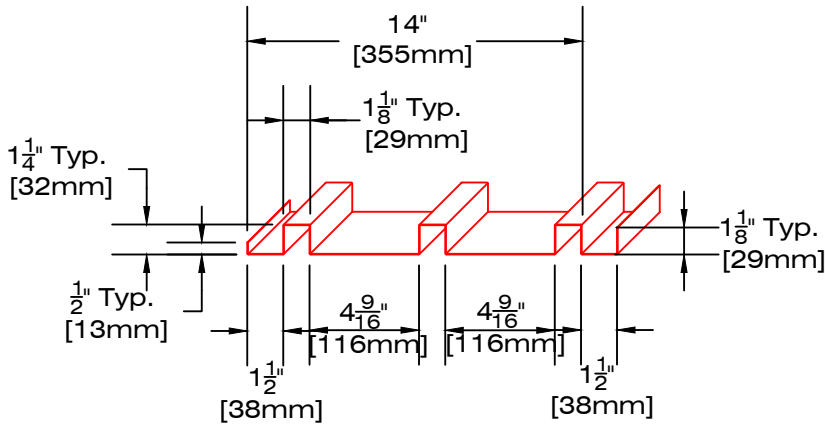

MODEL PR-132

3x A ribs 1 1/4" height
 Width 14" (57%)
 Blank 24 5/8" (x 2 = 49 1/4")

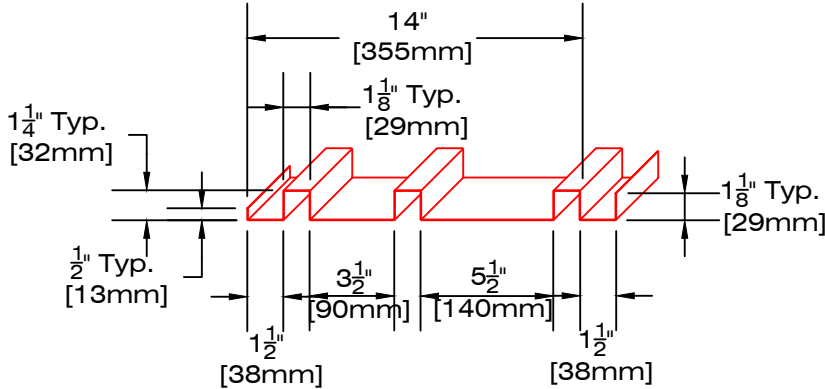

MODEL PR-133

3x A ribs 1 1/4" height
 Width 14" (57%)
 Blank 24 5/8" (x 2 = 49 1/4")

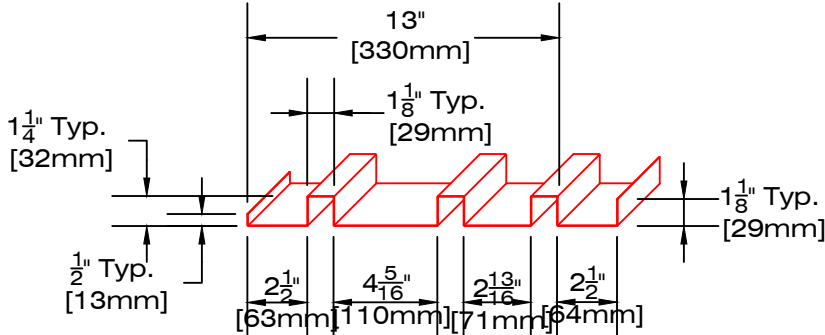

MODEL PR-134

3x A ribs 1 1/4" height
 Width 13" (53%)
 Blank 24 5/8" (x 2 = 49 1/4")

LES INDUSTRIES



49, boul. de la Seigneurie Est
 Blainville (Québec) J7C 4G6

Phone : (450) 430-3029

www.panfab.com

Project:

PR-100 PANFAB PROFILE

Title:

PR-130 VERTICAL RECTANGULAR RIBBING

Scale:

1:8

Page:

100130

Date:

JANUARY 2023

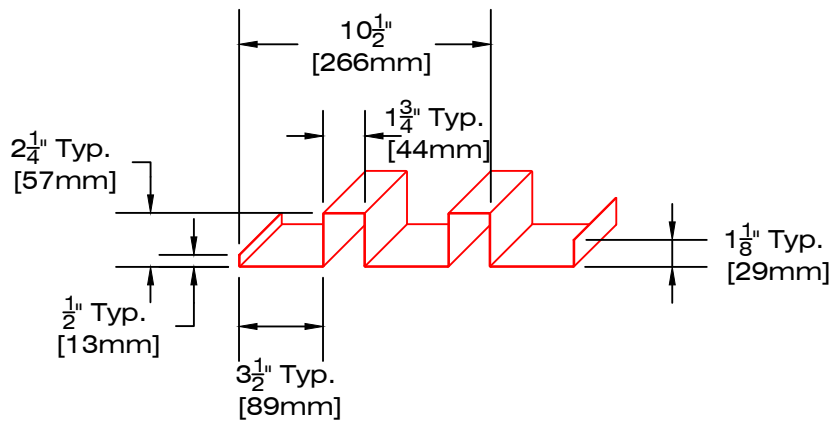

MODEL PR-135

2x B ribs 2 1/4" height
 Width 10 1/2" (43%)
 Blank 24 5/8" (x 2 = 49 1/4")

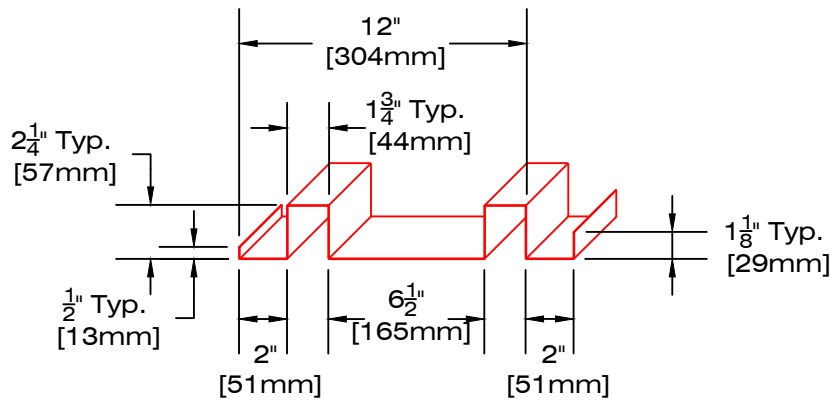

MODEL PR-136

2x B ribs 2 1/4" height
 Width 12" (49%)
 Blank 24 5/8" (x 2 = 49 1/4")

LES INDUSTRIES



49, boul. de la Seigneurie Est
 Blainville (Québec) J7C 4G6

Phone : (450) 430-3029

www.panfab.com

Project:

PR-100 PANFAB PROFILE

Title:

PR-130 VERTICAL RECTANGULAR RIBBING

Scale:

1:8

Page:

100131

Date:

JANUARY 2023

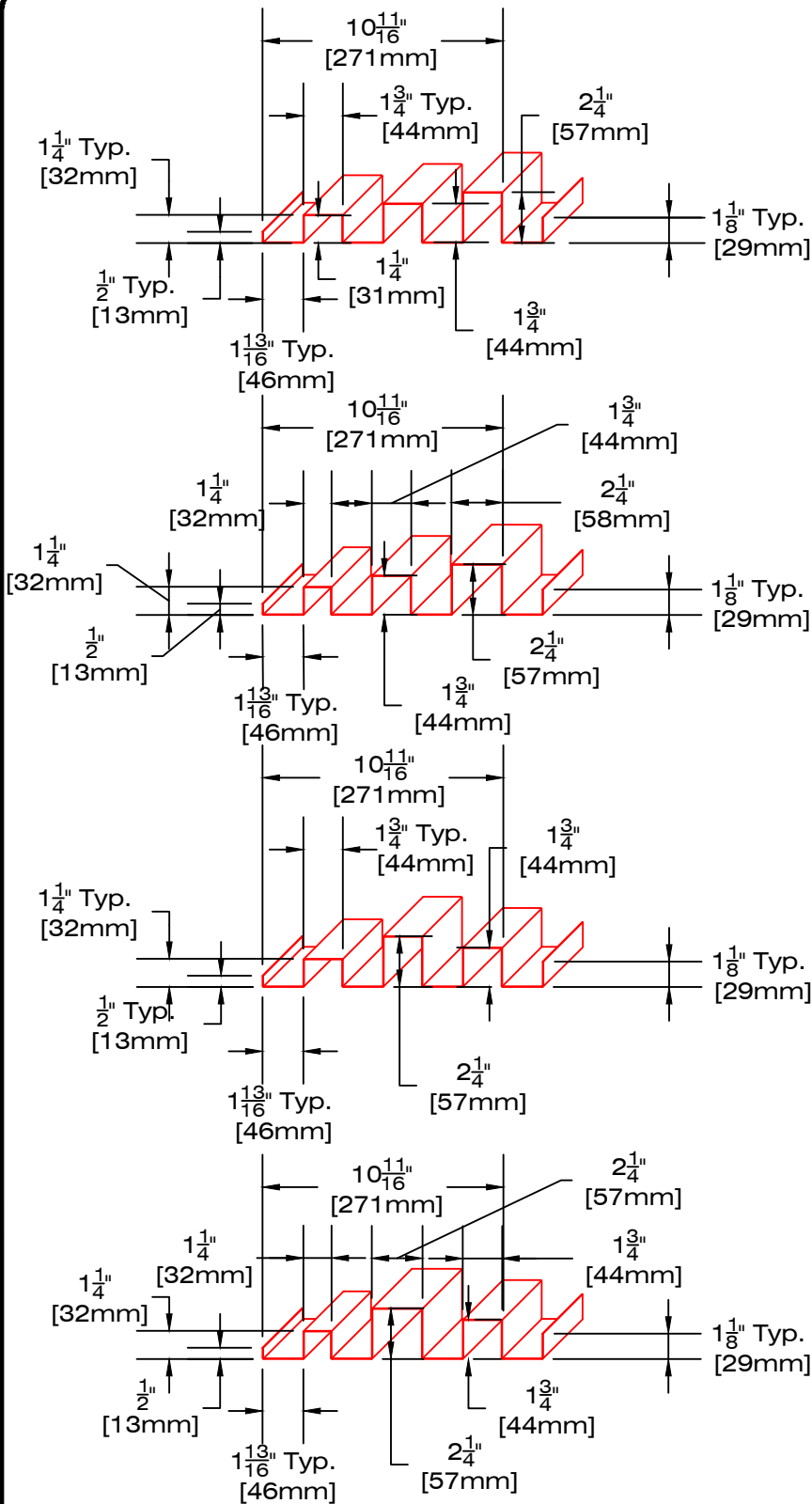

MODEL PR-141

- 1x A rib 1 1/4" height
- 1x B rib 2 1/4" height
- 1x C rib 1 3/4" height
- Width 10 11/16" (43%)
- Blank 24 5/8" (x 2 = 49 1/4")

MODEL PR-142

- 1x A rib 1 1/4" height
- 1x B rib 2 1/4" height
- 1x C rib 1 3/4" height
- Width 10 11/16" (43%)
- Blank 24 5/8" (x 2 = 49 1/4")

MODEL PR-143

- 1x A rib 1 1/4" height
- 1x B rib 2 1/4" height
- 1x C rib 1 3/4" height
- Width 10 11/16" (43%)
- Blank 24 5/8" (x 2 = 49 1/4")

MODEL PR-144

- 1x A rib 1 1/4" height
- 1x B rib 2 1/4" height
- 1x C rib 1 3/4" height
- Width 10 11/16" (43%)
- Blank 24 5/8" (x 2 = 49 1/4")

LES INDUSTRIES



49, boul. de la Seigneurie Est
Blainville (Québec) J7C 4G6

Phone : (450) 430-3029

www.panfab.com

Project:

PR-100 PANFAB PROFILE

Title:

PR-140 VARIABLE RECTANGULAR RIBBING

Scale:

1:8

Date:

JANUARY 2023

Page:

100140

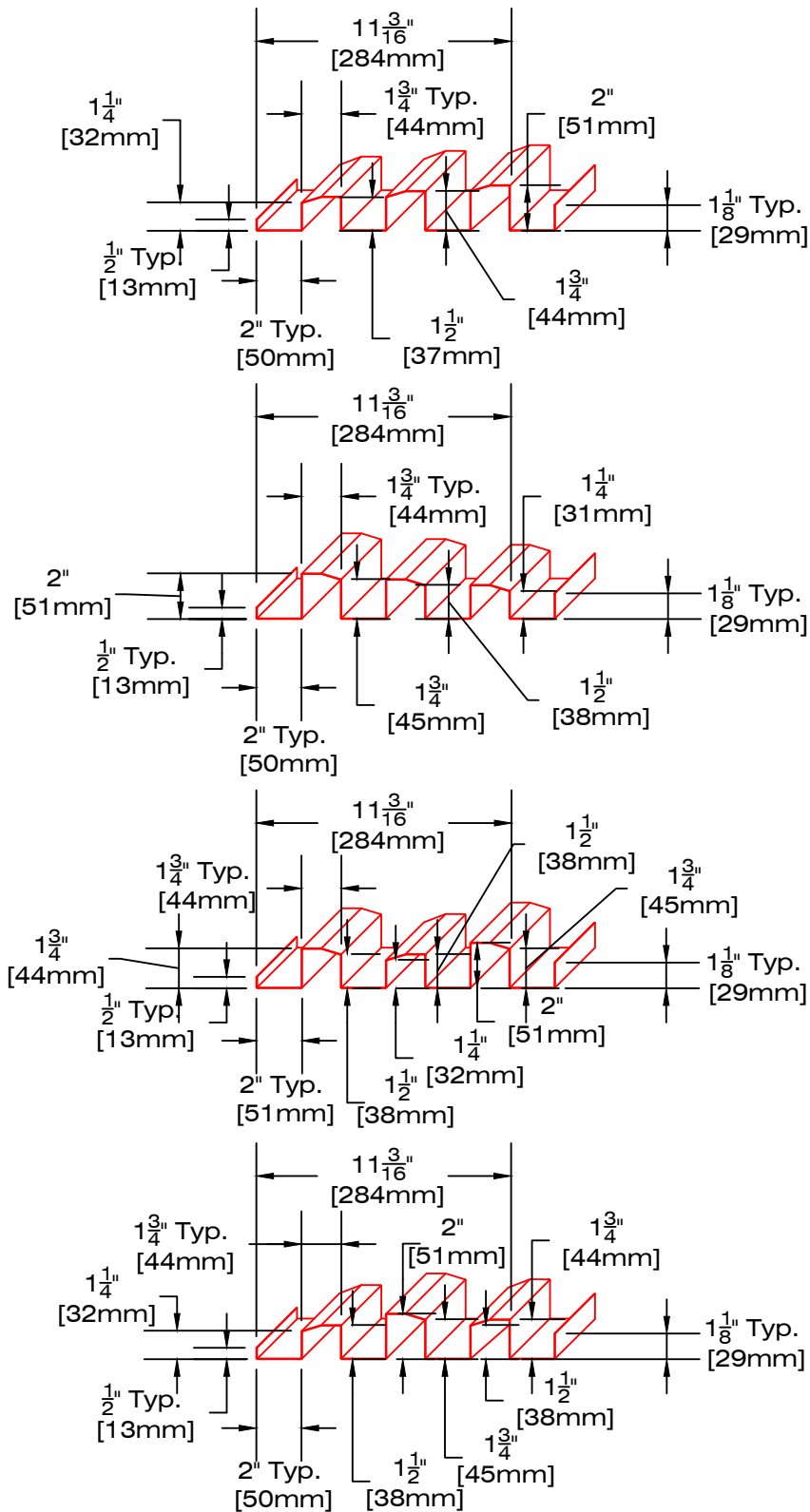

MODEL PR-151

1x D rib 1 1/4" @ 1 1/2" height
 1x E rib 1 1/2" @ 1 3/4" height
 1x F rib 1 3/4" @ 2" height
 Width 11.178" (45%)
 Blank 24 5/8" (x 2 = 49 1/4")

MODEL PR-152

1x D rib 1 1/4" @ 1 1/2" height
 1x E rib 1 1/2" @ 1 3/4" height
 1x F rib 1 3/4" @ 2" height
 Width 11.178" (45%)
 Blank 24 5/8" (x 2 = 49 1/4")

MODEL PR-153

1x D rib 1 1/4" @ 1 1/2" height
 1x E rib 1 1/2" @ 1 3/4" height
 1x F rib 1 3/4" @ 2" height
 Width 11.178" (45%)
 Blank 24 5/8" (x 2 = 49 1/4")

MODEL PR-154

1x D rib 1 1/4" @ 1 1/2" height
 1x E rib 1 1/2" @ 1 3/4" height
 1x F rib 1 3/4" @ 2" height
 Width 11.178" (45%)
 Blank 24 5/8" (x 2 = 49 1/4")

LES INDUSTRIES



49, boul. de la Seigneurie Est
 Blainville (Québec) J7C 4G6

Phone : (450) 430-3029

www.panfab.com

Project:

PR-100 PANFAB PROFILE

Title:

MODEL PR-150 TRAPEZOID RIBBING

Scale:

1:8

Page:

100150

Date:

JANUARY 2023

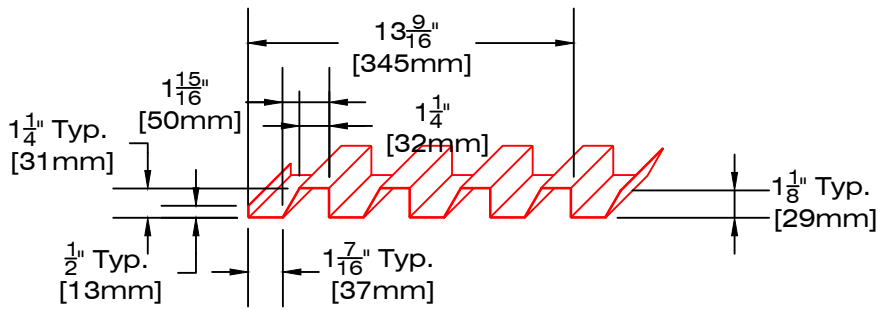

MODEL PR-161

4x A ribs 1 1/4" height
 Width 13 9/16" (55%)
 Blank 24 5/8" (x 2 = 49 1/4")

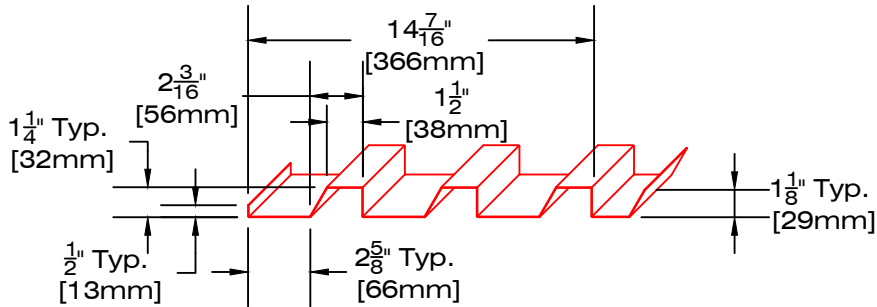

MODEL PR-162

3x A ribs 1 1/4" height
 Width 14 7/16" (59%)
 Blank 24 5/8" (x 2 = 49 1/4")

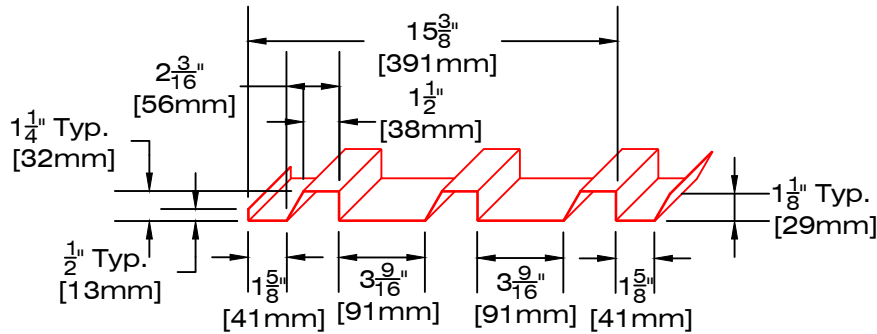

MODEL PR-163

3x A ribs 1 1/4" height
 Width 15 3/8" (62%)
 Blank 24 5/8" (x 2 = 49 1/4")

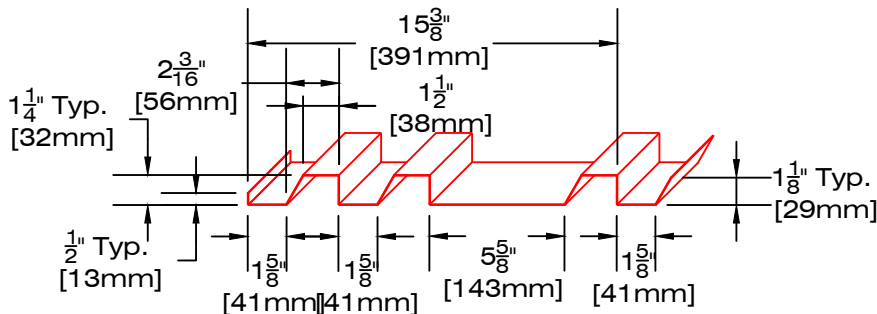

MODEL PR-164

3x A ribs 1 1/4" height
 Width 15 3/8" (62%)
 Blank 24 5/8" (x 2 = 49 1/4")

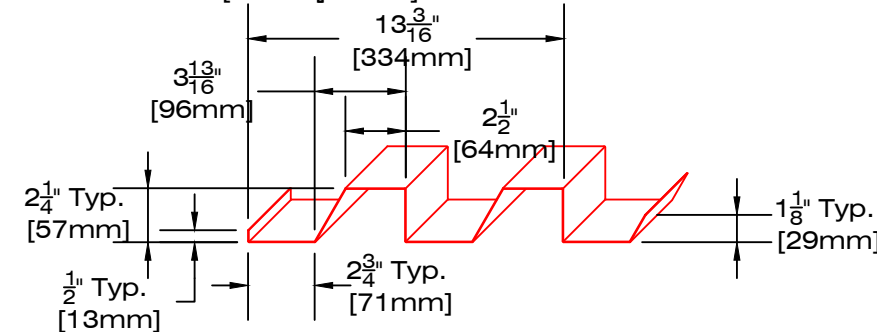

MODEL PR-165

2x B ribs 2 1/4" height
 Width 13 3/16" (53%)
 Blank 24 5/8" (x 2 = 49 1/4")

LES INDUSTRIES



49, boul. de la Seigneurie Est
 Blainville (Québec) J7C 4G6

Phone : (450) 430-3029

www.panfab.com

Project:

PR-100 PANFAB PROFILE

Title:

MODEL PR-160 1 ANGLE RIBBING

Scale:

1:8

Date:

JANUARY 2023

Page:

100160

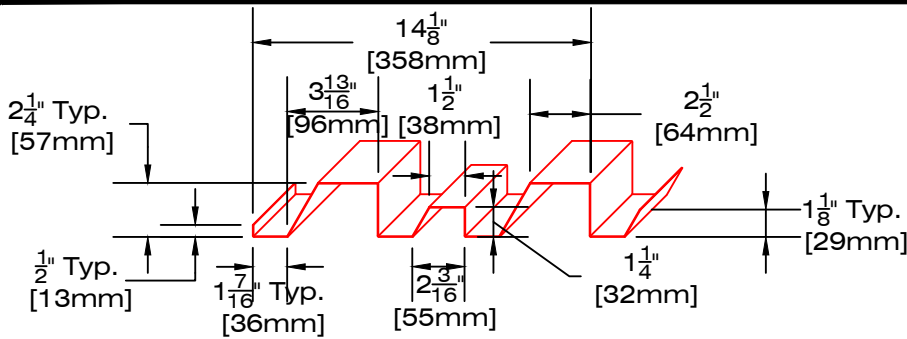

MODEL PR-166A

1x A rib 1 1/4" height
 2x B ribs 2 1/4" height
 Width 14 1/8" (54%)
 Blank 26 3/16" (+ 23 1/16" = 49 1/4")

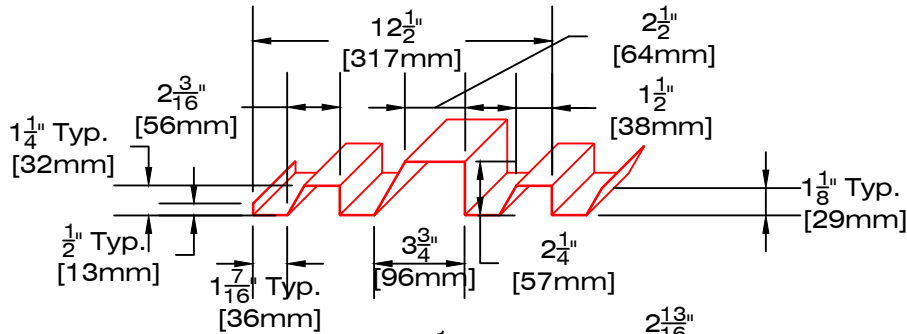

MODEL PR-166B

2x A ribs 1 1/4" height
 1x B rib 2 1/4" height
 Width 12 1/2" (54%)
 Blank 23 1/16" (+ 26 3/16" = 49 1/4")

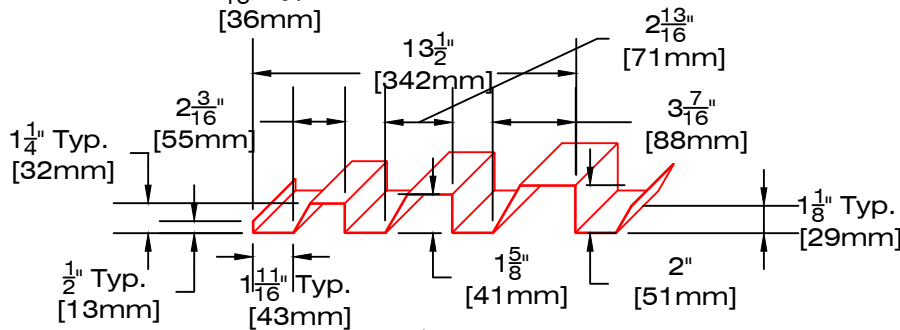

MODEL PR-167

1x A rib 1 1/4" height
 1x D rib 1 5/8" height
 1x E rib 2" height
 Width 13 1/2" (55%)
 Blank 24 5/8" (x 2 = 49 1/4")

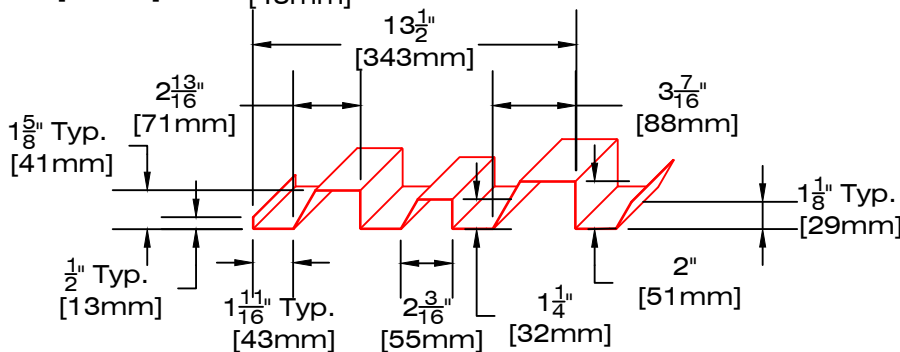

MODEL PR-168

1x A rib 1 1/4" height
 1x D rib 1 5/8" height
 1x E rib 2" height
 Width 13 1/2" (55%)
 Blank 24 5/8" (x 2 = 49 1/4")

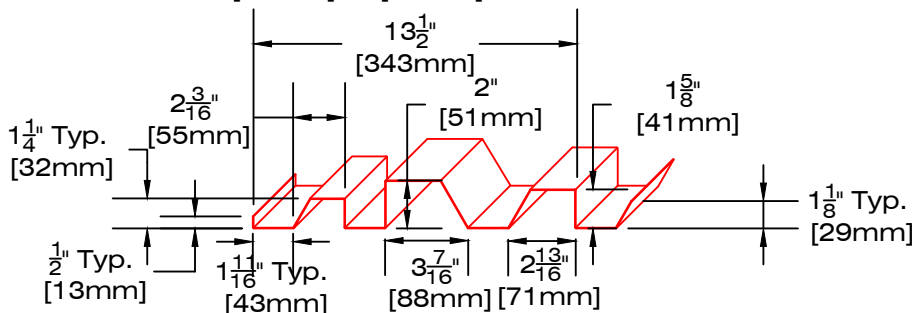

MODEL PR-169

1x A rib 1 1/4" height
 1x D rib 1 5/8" height
 1x E rib 2" height
 Width 13 1/2" (55%)
 Blank 24 5/8" (x 2 = 49 1/4")

LES INDUSTRIES



49, boul. de la Seigneurie Est
 Blainville (Québec) J7C 4G6

Phone : (450) 430-3029

www.panfab.com

Project:

PR-100 PANFAB PROFILE

Title:

MODEL PR-160 1 ANGLE RIBBING

Scale:

1:8

Page:

100161

Date:

JANUARY 2023

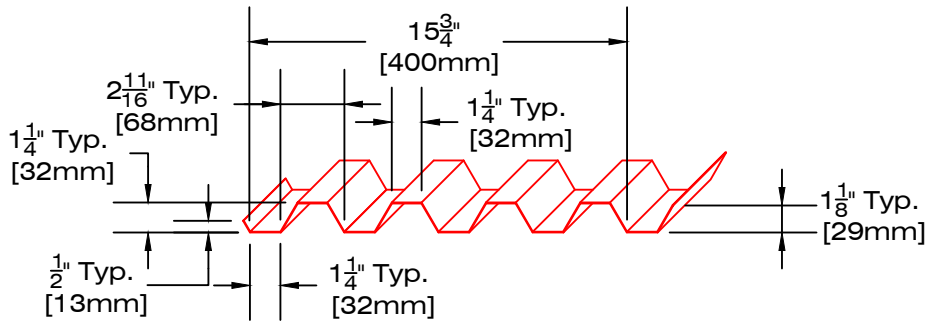

MODEL PR-171-30

4x A ribs 1 1/4" height
 Width 15 3/4" (64%)
 Blank 24 5/8" (x 2 = 49 1/4")

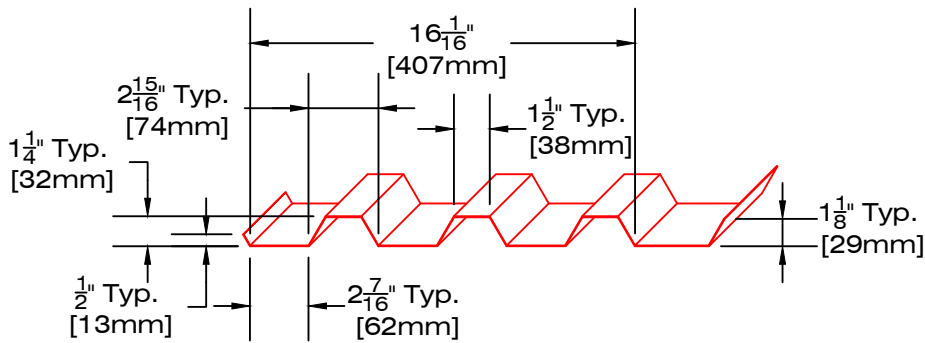

MODEL PR-172-30

3x A ribs 1 1/4" height
 Width 16 1/16" (65%)
 Blank 24 5/8" (x 2 = 49 1/4")

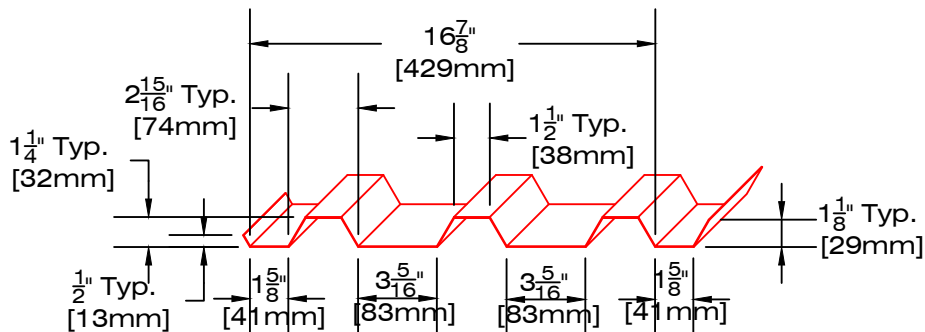

MODEL PR-173-30

3x A ribs 1 1/4" height
 Width 16 7/8" (69%)
 Blank 24 5/8" (x 2 = 49 1/4")

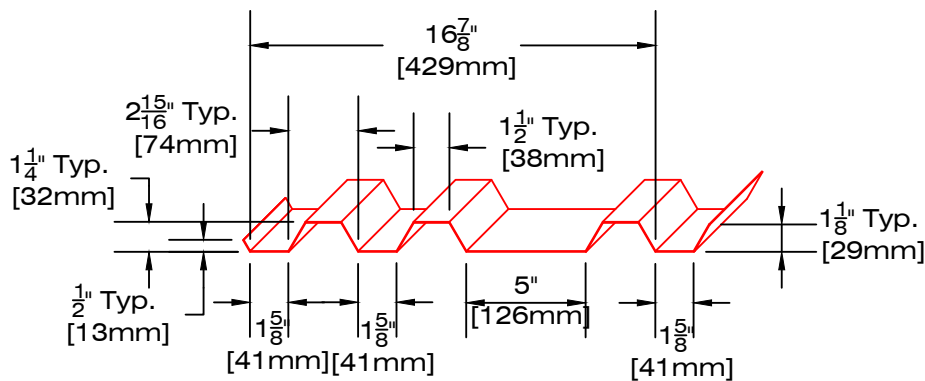

MODEL PR-174-30

3x A ribs 1 1/4" height
 Width 16 7/8" (69%)
 Blank 24 5/8" (x 2 = 49 1/4")

LES INDUSTRIES



49, boul. de la Seigneurie Est
 Blainville (Québec) J7C 4G6

Phone : (450) 430-3029

www.panfab.com

Project:

PR-100 PANFAB PROFILE

Title:

MODEL PR-170 2 ANGLES RIBBING

Scale:

1:8

Date:

JANUARY 2023

Page:

100170

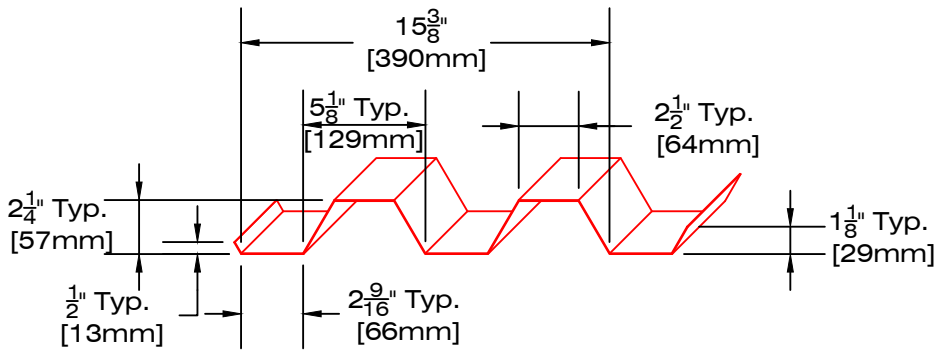

MODEL PR-175-30

2x B ribs 2 1/4" height
 Width 15 3/8" (62%)
 Blank 24 5/8" (x 2 = 49 1/4")

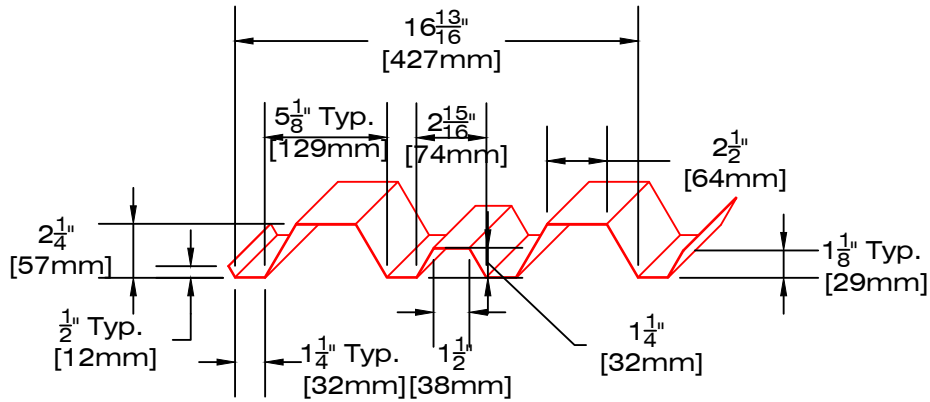

MODEL PR-176A-30

1x A rib 1 1/4" height
 2x B ribs 2 1/4" height
 Width 16 13/16" (64%)
 Blank 26 3/8" (+ 22 7/8" = 49 1/4")

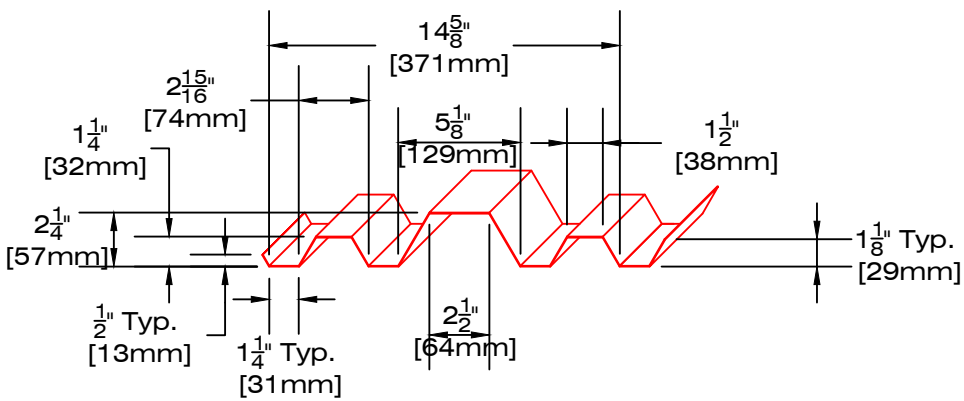

MODEL PR-176B-30

2x A ribs 1 1/4" height
 1x B rib 2 1/4" height
 Width 14 5/8" (64%)
 Blank 22 7/8" (+ 26 3/8" = 49 1/4")



49, boul. de la Seigneurie Est
 Blainville (Québec) J7C 4G6

Phone : (450) 430-3029

www.panfab.com

Project:		PR-100 PANFAB PROFILE	
Title:		MODEL PR-170 2 ANGLES RIBBING	
Scale:	1:8	Page:	100171
Date:	JANUARY 2023		

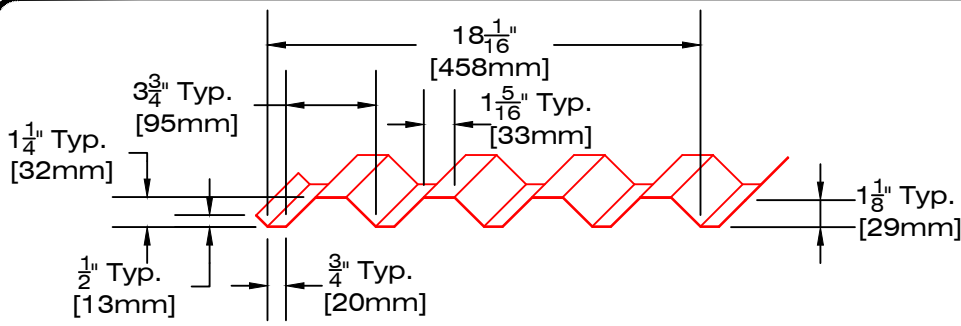

MODEL PR-171-45

4x A ribs 1 $\frac{1}{4}"$ height
 Width 18 $\frac{1}{16}"$ (73%)
 Blank 24 $\frac{5}{8}"$ (x 2 = 49 $\frac{1}{4}"$)

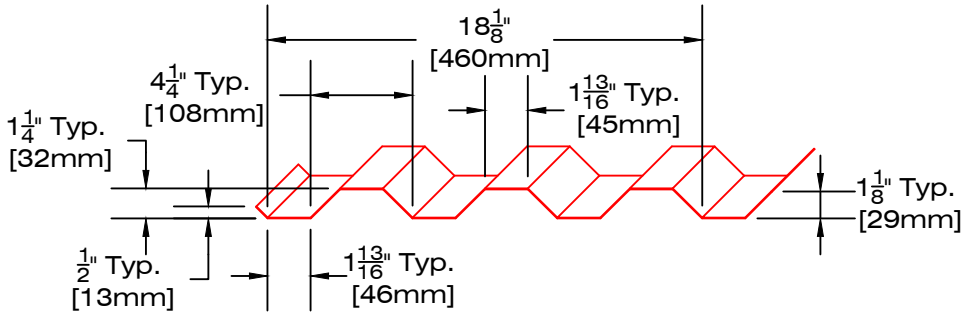

MODEL PR-172-45

3x A ribs 1 $\frac{1}{4}"$ height
 Width 18 $\frac{1}{8}"$ (74%)
 Blank 24 $\frac{5}{8}"$ (x 2 = 49 $\frac{1}{4}"$)

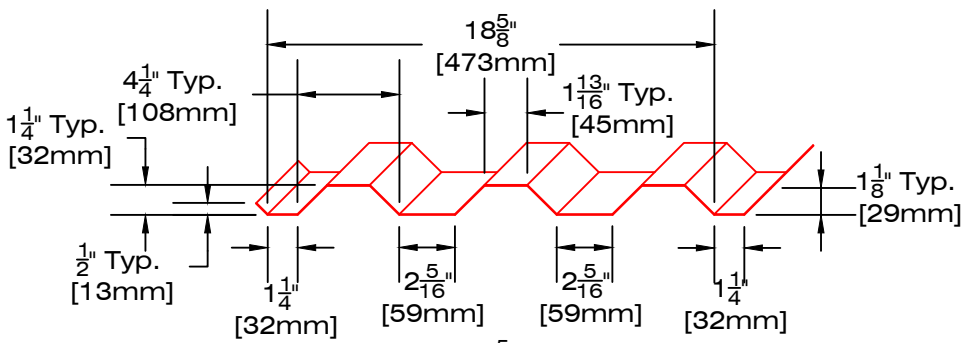

MODEL PR-173-45

3x A ribs 1 $\frac{1}{4}"$ height
 Width 18 $\frac{5}{8}"$ (76%)
 Blank 24 $\frac{5}{8}"$ (x 2 = 49 $\frac{1}{4}"$)

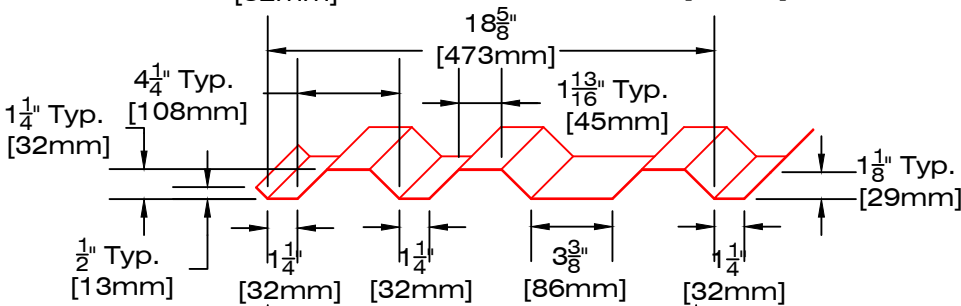

MODEL PR-174-45

3x A ribs 1 $\frac{1}{4}"$ height
 Width 18 $\frac{5}{8}"$ (76%)
 Blank 24 $\frac{5}{8}"$ (x 2 = 49 $\frac{1}{4}"$)

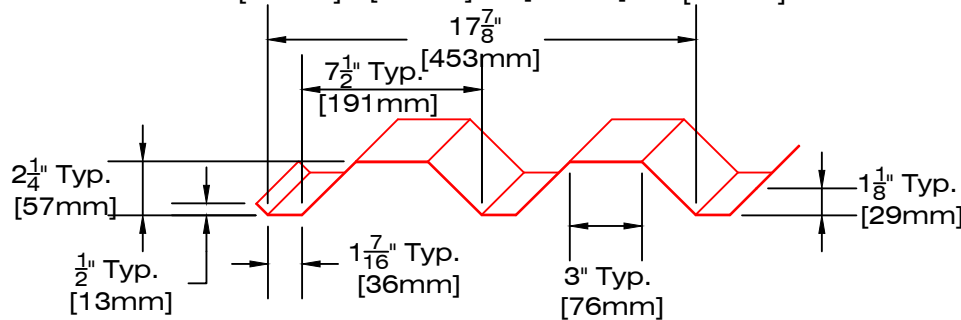

MODEL PR-175-45

2x B ribs 2 $\frac{1}{4}"$ height
 Width 17 $\frac{7}{8}"$ (73%)
 Blank 24 $\frac{5}{8}"$ (x 2 = 49 $\frac{1}{4}"$)

LES INDUSTRIES



49, boul. de la Seigneurie Est
 Blainville (Québec) J7C 4G6

Phone : (450) 430-3029

www.panfab.com

Project:

PR-100 PANFAB PROFILE

Title:

MODEL PR-170 2 ANGLES RIBBING

Scale:

1:8

Page:

100172

Date:

JANUARY 2023

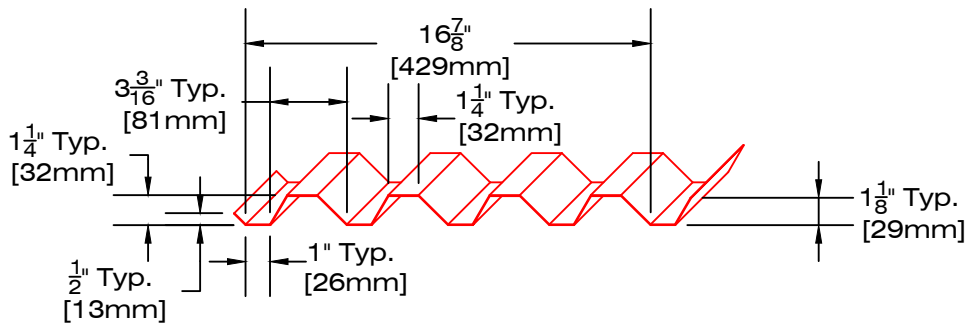

MODEL PR-171-COMB

4x A ribs 1 1/4" height
 Width 16 7/8" (69%)
 Blank 24 5/8" (x 2 = 49 1/4")

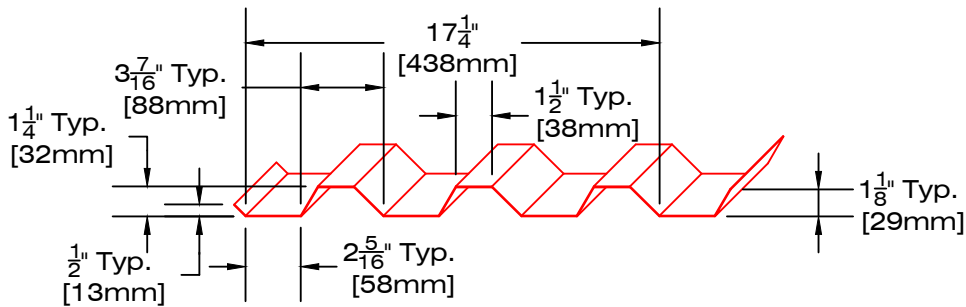

MODEL PR-172-COMB

3x A ribs 1 1/4" height
 Width 17 1/4" (70%)
 Blank 24 5/8" (x 2 = 49 1/4")

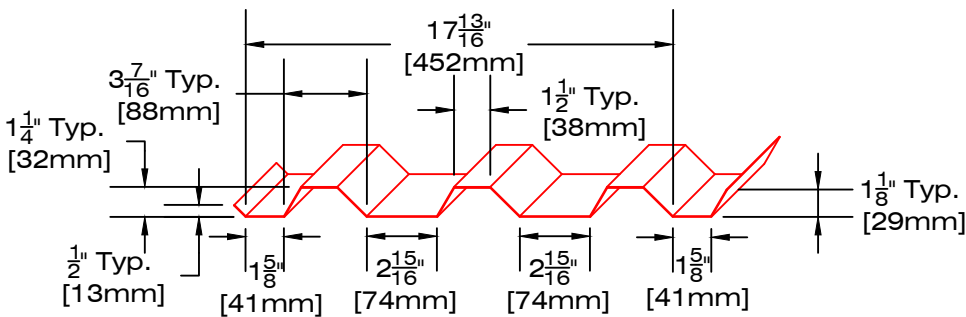

MODEL PR-173-COMB

3x A ribs 1 1/4" height
 Width 17 13/16" (72%)
 Blank 24 5/8" (x 2 = 49 1/4")

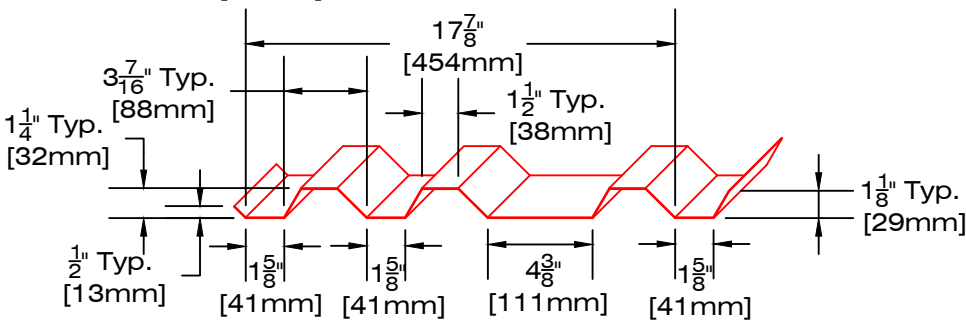

MODEL PR-174-COMB

3x A ribs 1 1/4" height
 Width 17 7/8" (73%)
 Blank 24 5/8" (x 2 = 49 1/4")

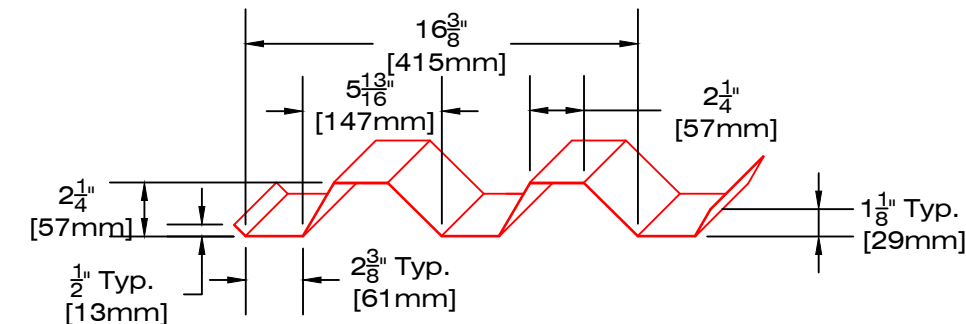

MODEL PR-175-COMB

2x B ribs 2 1/4" height
 Width 16 3/8" (66%)
 Blank 24 5/8" (x 2 = 49 1/4")

LES INDUSTRIES



49, boul. de la Seigneurie Est
 Blainville (Québec) J7C 4G6

Phone : (450) 430-3029

www.panfab.com

Project:

PR-100 PANFAB PROFILE

Title:

MODEL PR-170 2 ANGLES RIBBING

Scale:

1:8

Page:

100173

Date:

JANUARY 2023

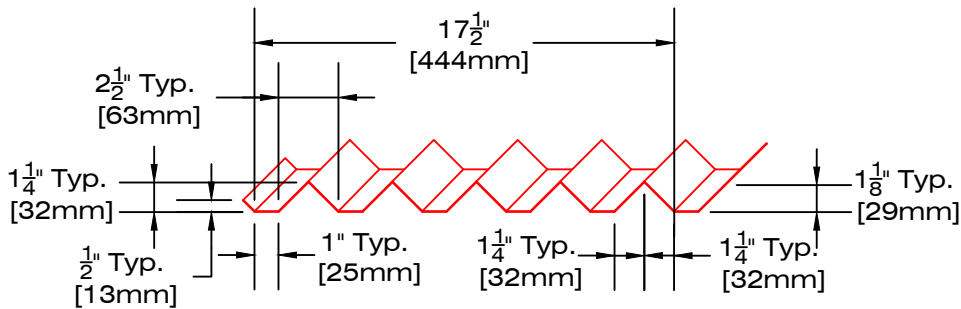

MODEL PR-181

5x A ribs 1 1/4" height
 Width 17 1/2" (71%)
 Blank 24 5/8" (x 2 = 49 1/4")

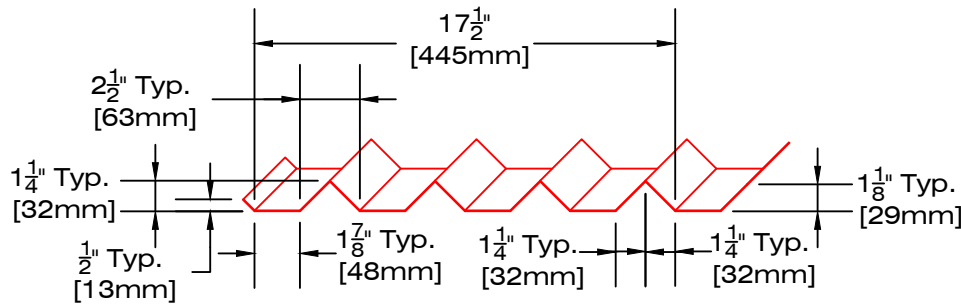

MODEL PR-182

4x A ribs 1 1/4" height
 Width 17 1/2" (71%)
 Blank 24 5/8" (x 2 = 49 1/4")

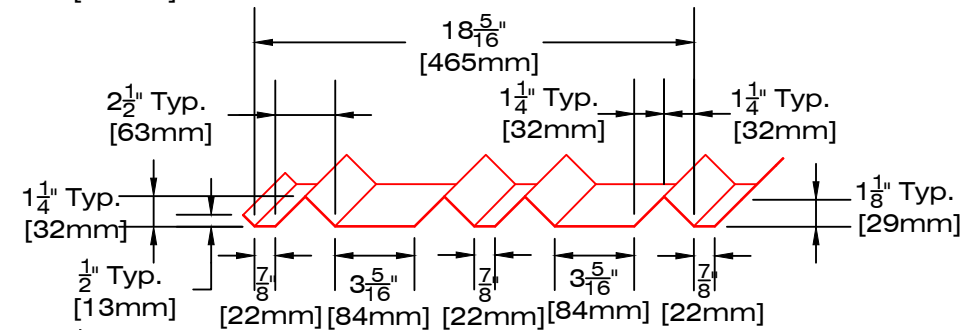

MODEL PR-183

4x A ribs 1 1/4" height
 Width 18 5/16" (74%)
 Blank 24 5/8" (x 2 = 49 1/4")

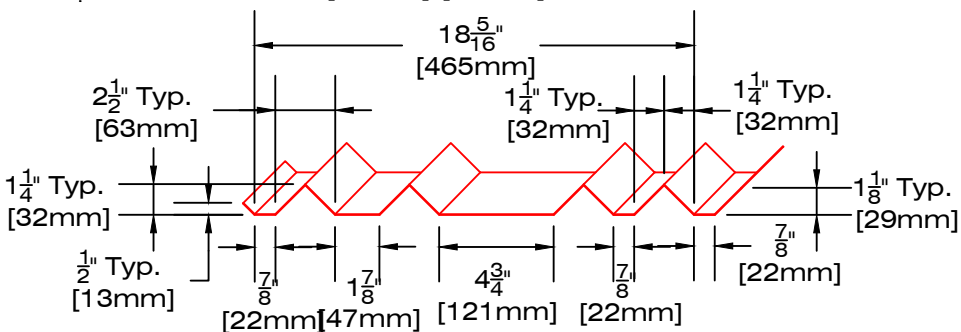

MODEL PR-184

4x A ribs 1 1/4" height
 Width 18 5/16" (74%)
 Blank 24 5/8" (x 2 = 49 1/4")

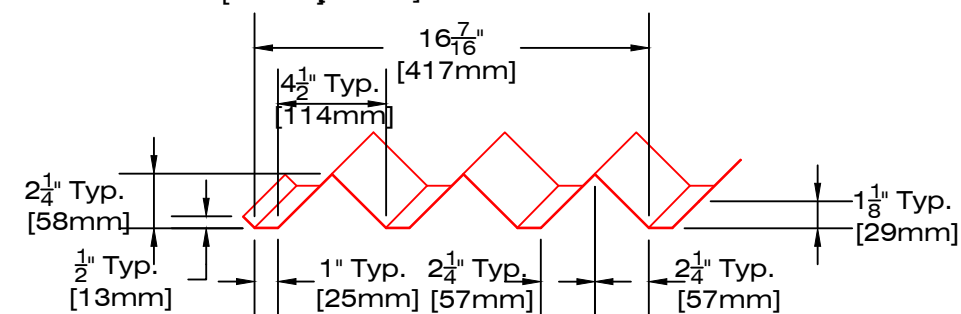

MODEL PR-185

3x B ribs 2 1/4" height
 Width 16 7/16" (67%)
 Blank 24 5/8" (x 2 = 49 1/4")

LES INDUSTRIES



49, boul. de la Seigneurie Est
 Blainville (Québec) J7C 4G6

Phone : (450) 430-3029

www.panfab.com

Project:

PR-100 PANFAB PROFILE

Title:

MODEL PR-180 TRIANGULAR RIBBING

Scale:

1:8

Page:

100180

Date:

JANUARY 2023

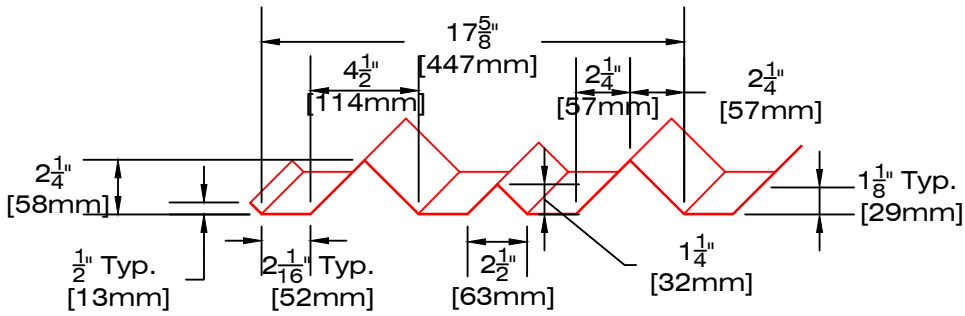

MODEL PR-186A

1x A rib 1 1/4" height
 2x B ribs 2 1/4" height
 Width 17 5/8" (67%)
 Blank 26 1/8" (+ 23 1/8" = 49 1/4")

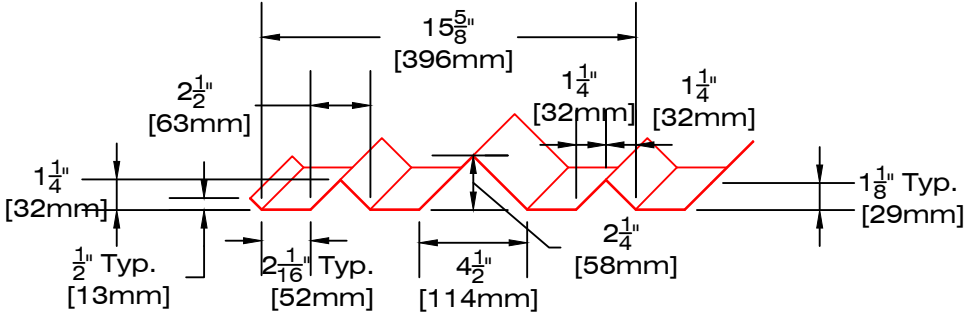

MODEL PR-186B

2x A ribs 1 1/4" height
 1x B rib 2 1/4" height
 Width 15 5/8" (68%)
 Blank 23 1/8" (+ 26 1/8" = 49 1/4")

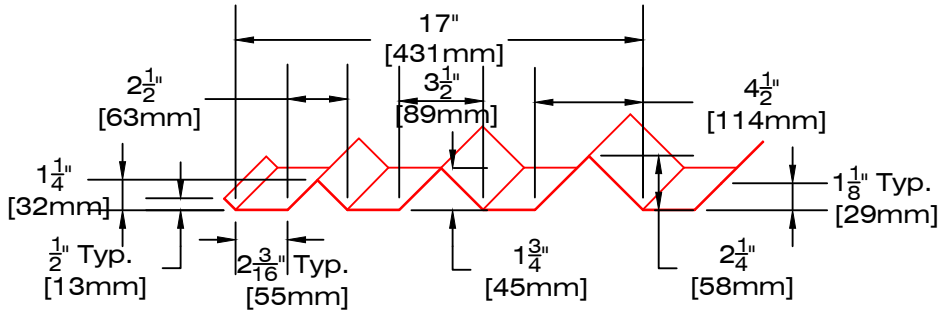

MODEL PR-187

1x A rib 1 1/4" height
 1x B rib 2 1/4" height
 1x C rib 1 3/4" height
 Width 17" (69%)
 Blank 24 5/8" (x 2 = 49 1/4")

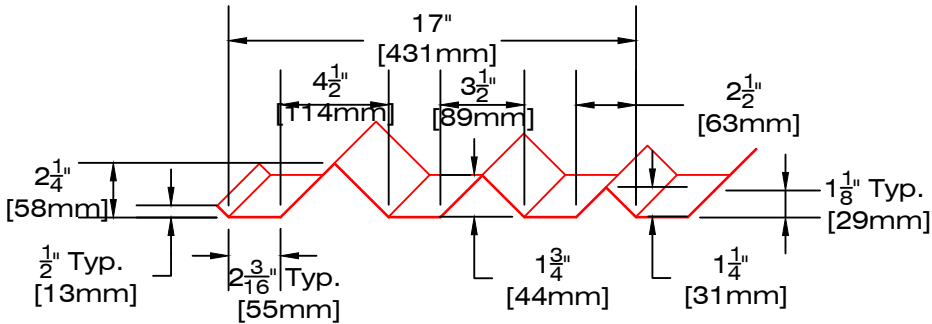

MODEL PR-188

1x A rib 1 1/4" height
 1x B rib 2 1/4" height
 1x C rib 1 3/4" height
 Width 17" (69%)
 Blank 24 5/8" (x 2 = 49 1/4")

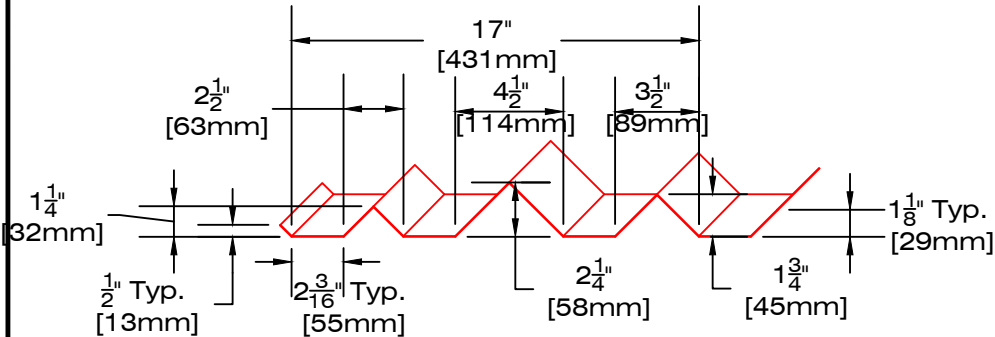

MODEL PR-189

1x A rib 1 1/4" height
 1x B rib 2 1/4" height
 1x C rib 1 3/4" height
 Width 17" (69%)
 Blank 24 5/8" (x 2 = 49 1/4")

LES INDUSTRIES



49, boul. de la Seigneurie Est
 Blainville (Québec) J7C 4G6

Phone : (450) 430-3029

www.panfab.com

Project:

PR-100 PANFAB PROFILE

Title:

MODEL PR-180 TRIANGULAR RIBBING

Scale:

1:8

Date:

JANUARY 2023

Page:

100181

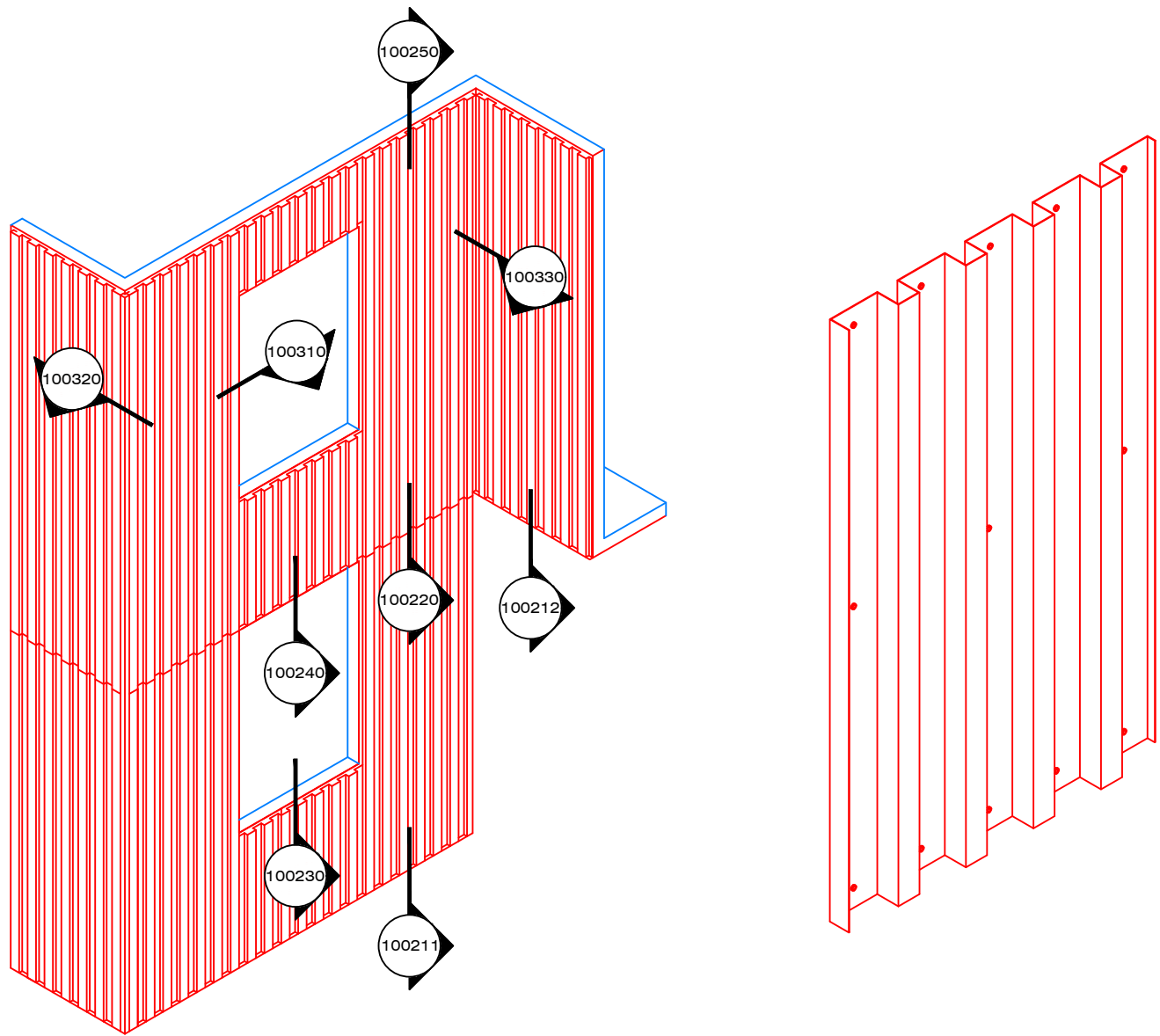

USE:

- Aluminium wall cladding (vertical or horizontal installation)

DESCRIPTION:

- Custom bent rib profile (63 different models)
- Custom width x length up to 13'-0" = 3962mm (min 6'-0" = 1829mm)
- Visible fasteners / screws at the bottom of the rib

FINISH OPTION:

- 0.8mm special alum. alloy 5754H42 with pre-painted "D-MAX" finish such as Duranar XL
- Choice of 7 standard inventory colors (White RAL9016, Jupiter RAL9006, Neptune, Alpha Centauri, Charcoal, Rigel-2 and Black RAL9005)
- Several exclusive finish options such as EuraBuild, EuraDesign, EuraMica, AluNatur (available on special orders of a minimum of 11 000 square feet with 0.8mm thickness)

LES INDUSTRIES



49, boul. de la Seigneurie Est
Blainville (Québec) J7C 4G6

Phone : (450) 430-3029

www.panfab.com

Project:

PR-100 PANFAB PROFILE

Title:

ISOMETRIC

Scale:

1:60 / 1:10

Date:

JANUARY 2023

Page:

100200

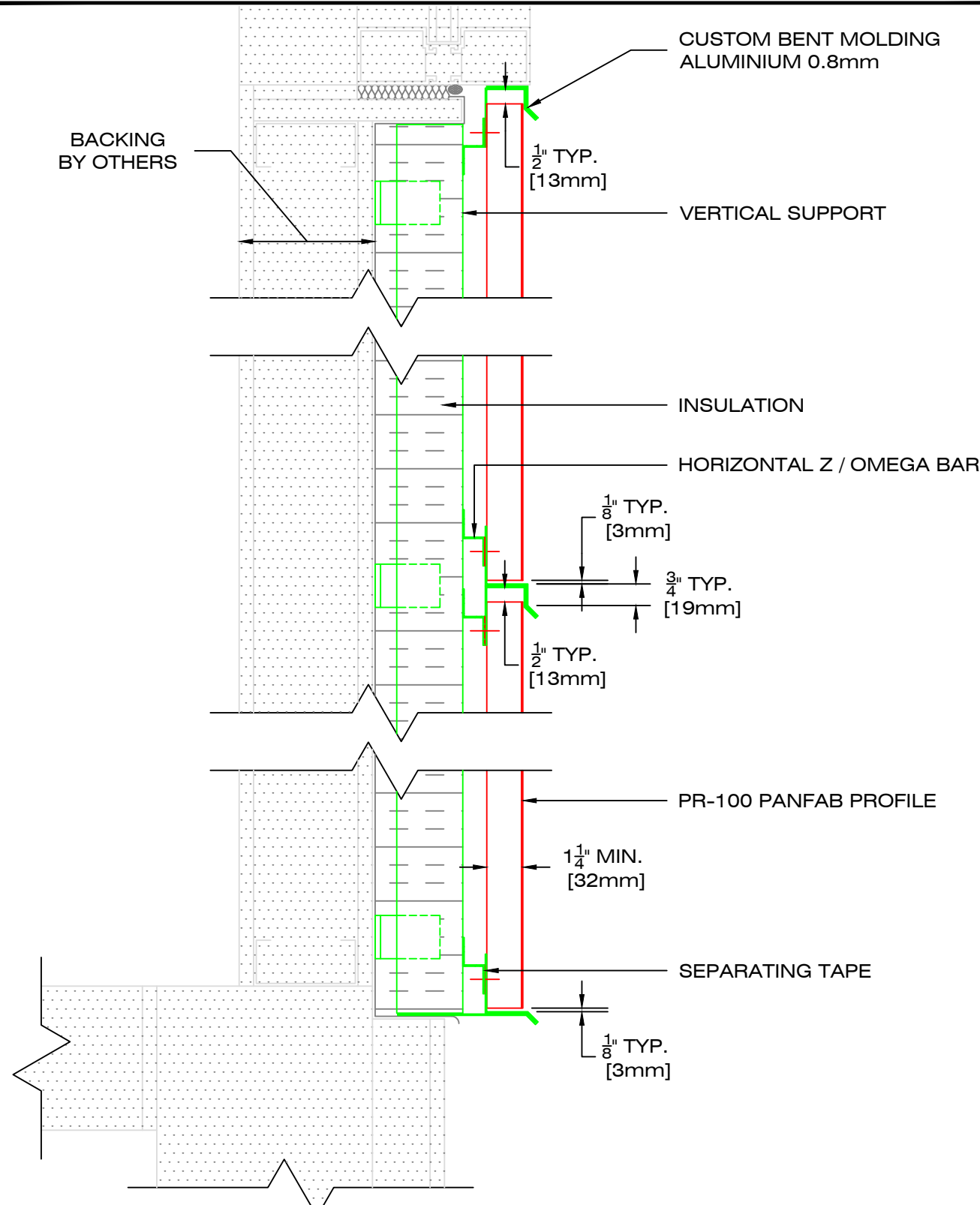

49, boul. de la Seigneurie Est
Blainville (Québec) J7C 4G6
Phone : (450) 430-3029
www.panfab.com

Project:	PR-100 PANFAB PROFILE	
Title:	SECTION - GENERAL	
Scale:	1:5	Page: 100210
Date:	JANUARY 2023	

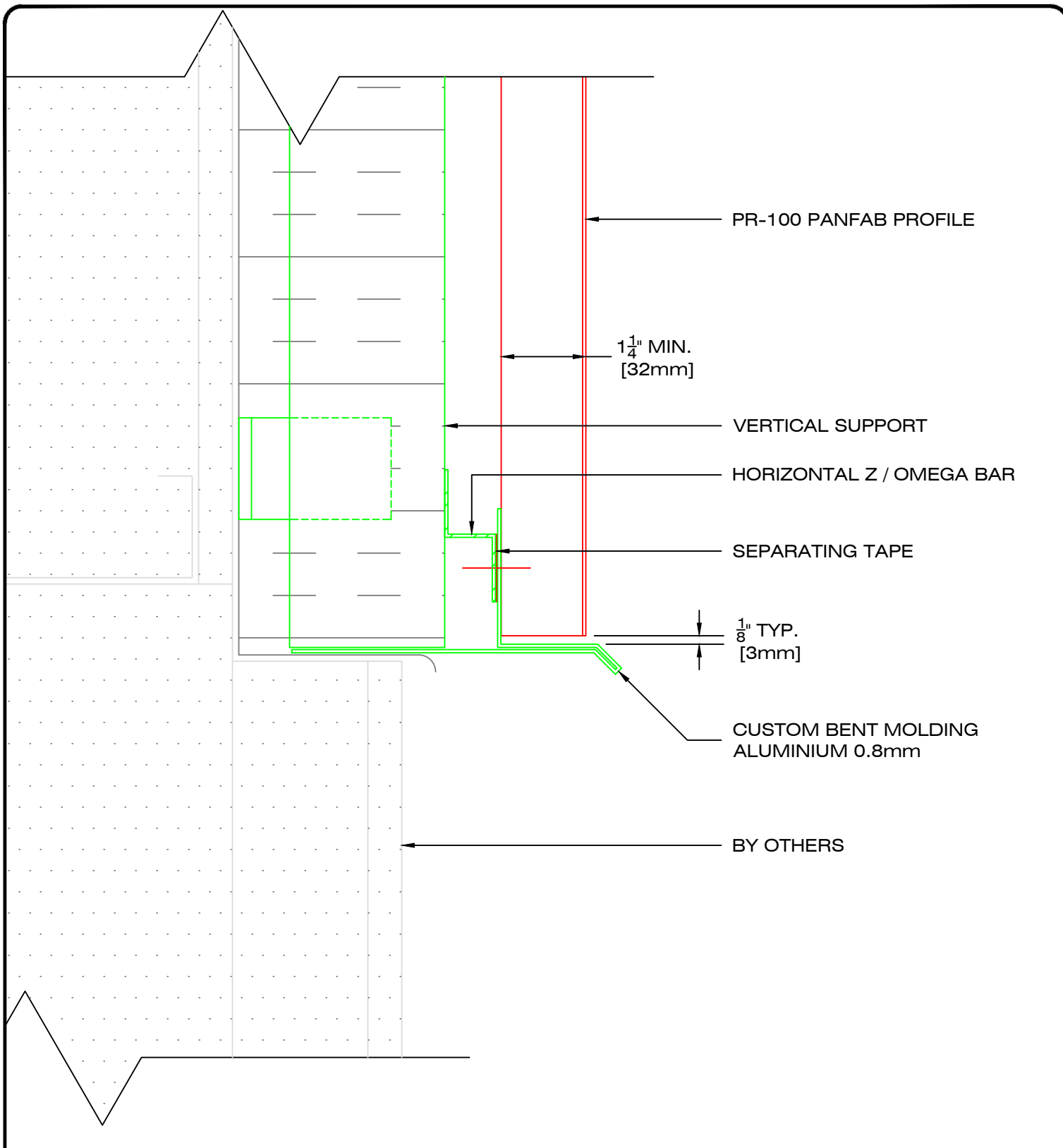

LES INDUSTRIES



49, boul. de la Seigneurie Est
Blainville (Québec) J7C 4G6

Phone : (450) 430-3029

www.panfab.com

Project:

PR-100 PANFAB PROFILE

Title:

SECTION - FOUNDATION

Scale:

1:2

Date:

JANUARY 2023

Page:

100211

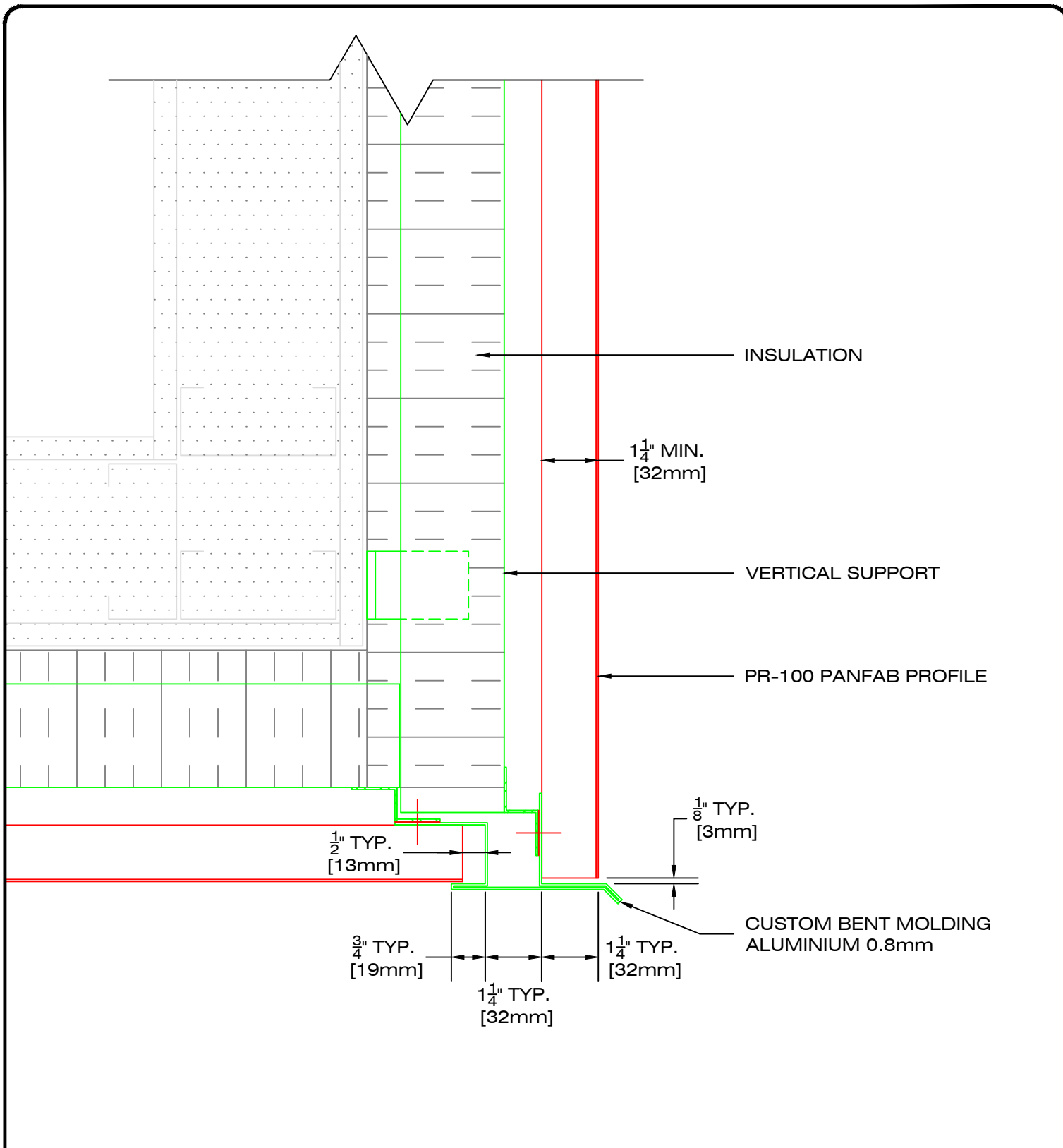

LES INDUSTRIES



49, boul. de la Seigneurie Est
Blainville (Québec) J7C 4G6

Phone : (450) 430-3029

www.panfab.com

Project:

PR-100 PANFAB PROFILE

Title:

SECTION - SOFFIT

Scale:

1:3

Date:

JANUARY 2023

Page:

100212

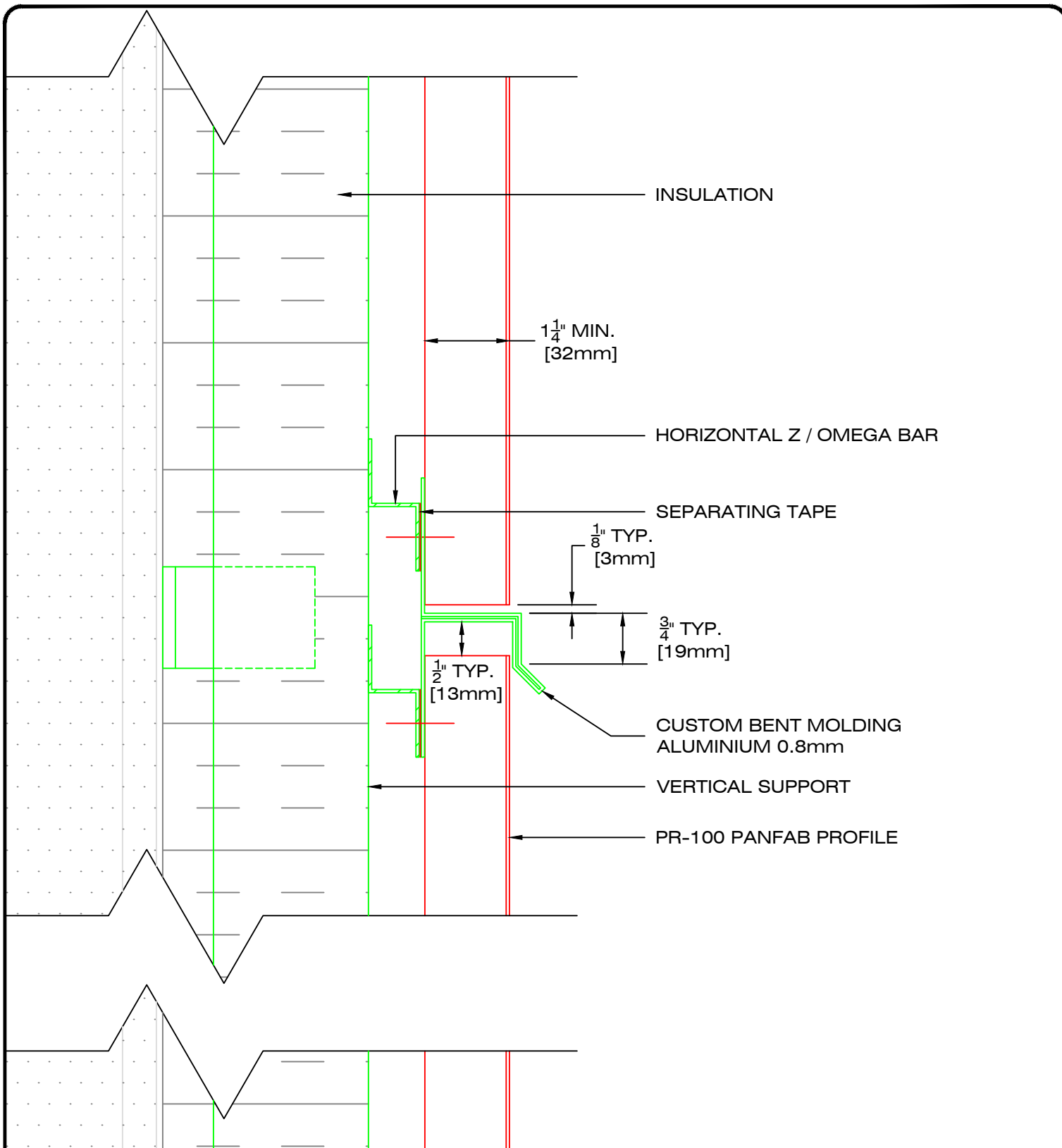

LES INDUSTRIES



49, boul. de la Seigneurie Est
Blainville (Québec) J7C 4G6

Phone : (450) 430-3029

www.panfab.com

Project:

PR-100 PANFAB PROFILE

Title:

SECTION - HORIZONTAL JOINT

Scale:

1:2

Page:

100220

Date:

JANUARY 2023

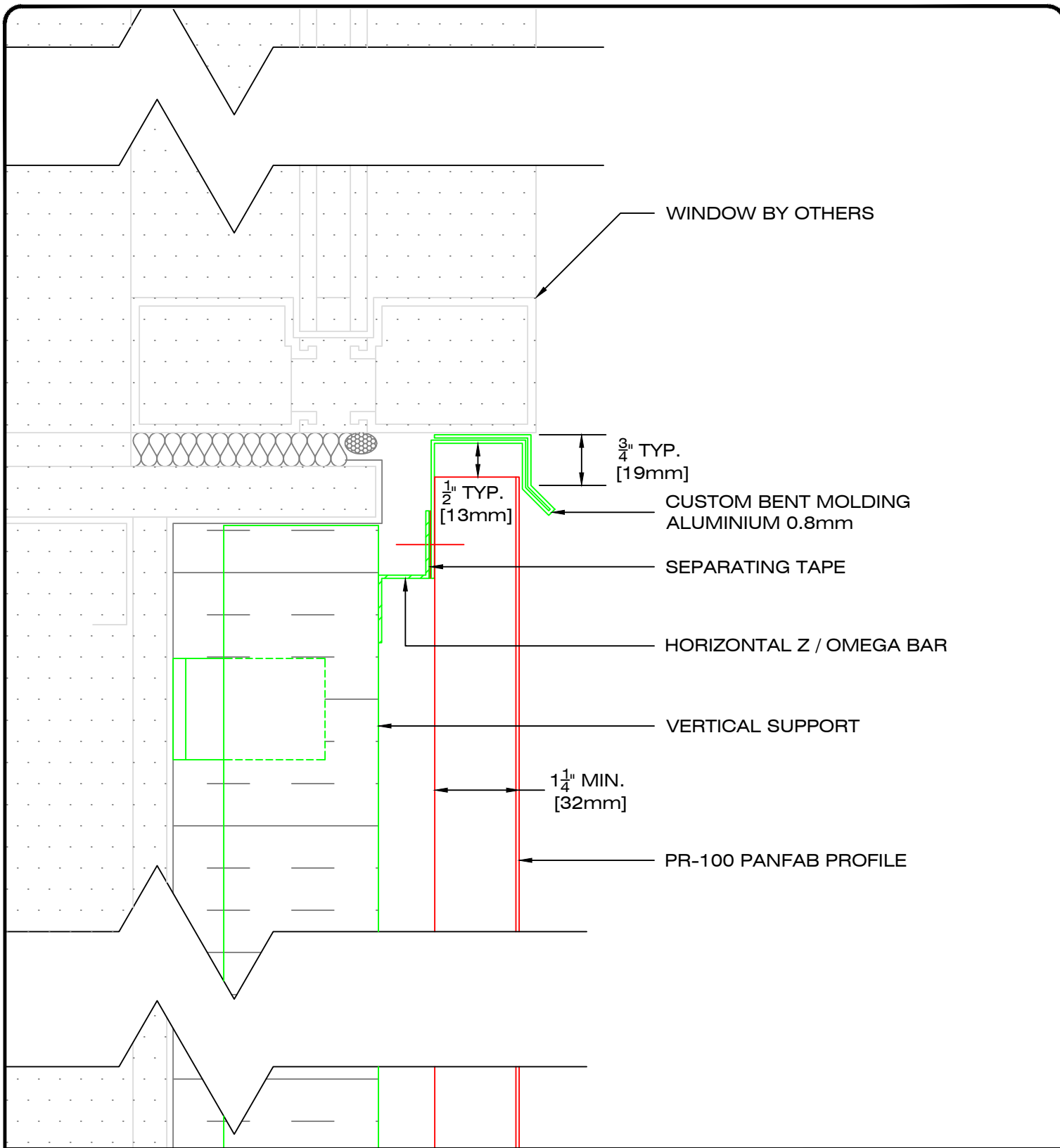

LES INDUSTRIES



49, boul. de la Seigneurie Est
Blainville (Québec) J7C 4G6

Phone : (450) 430-3029

www.panfab.com

Project:

PR-100 PANFAB PROFILE

Title:

SECTION - WINDOW SILL

Scale:

1:2

Page:

100230

Date:

JANUARY 2023

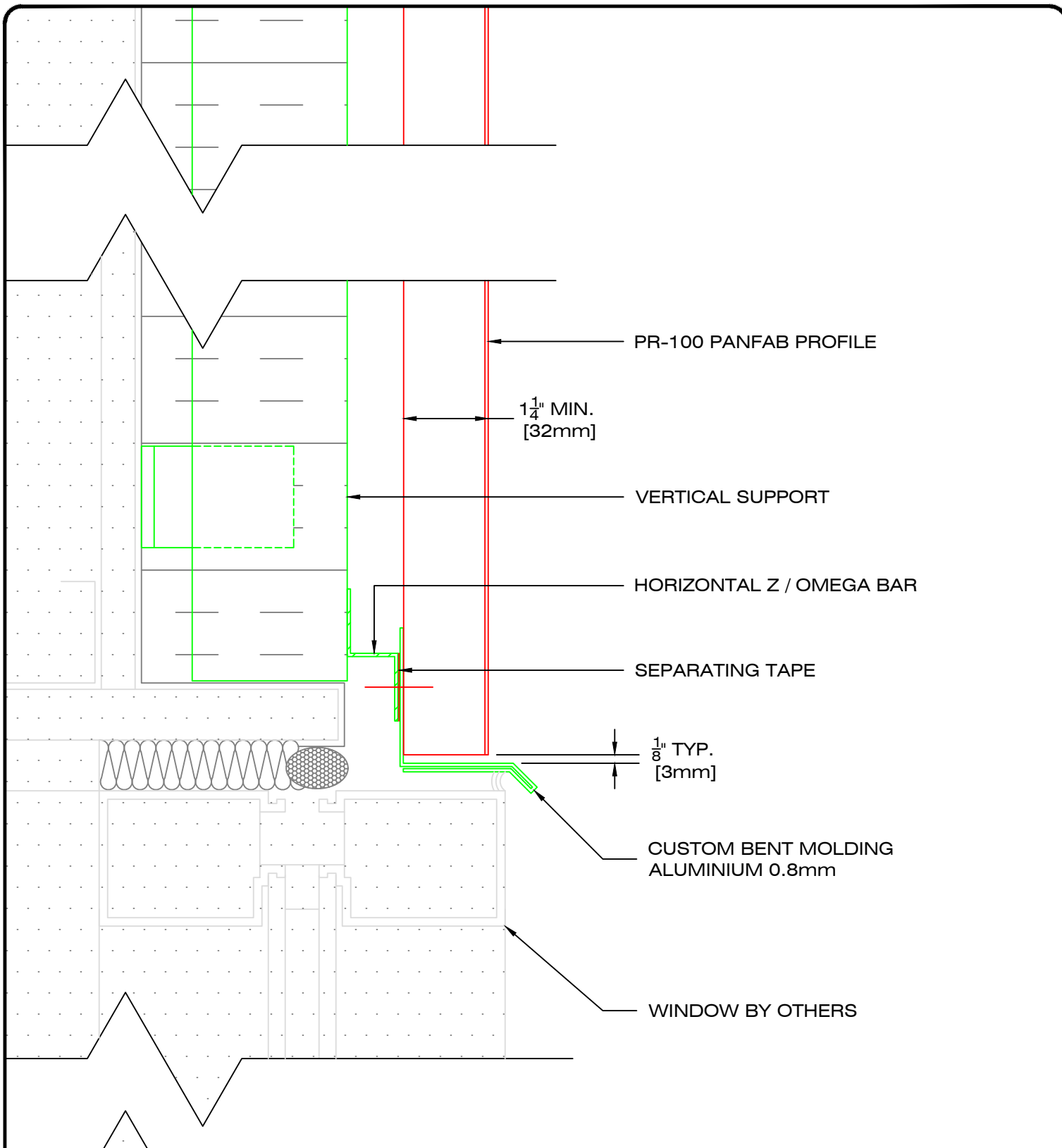

LES INDUSTRIES



49, boul. de la Seigneurie Est
Blainville (Québec) J7C 4G6

Phone : (450) 430-3029

www.panfab.com

Project:

PR-100 PANFAB PROFILE

Title:

SECTION - WINDOW LINTEL

Scale:

1:2

Date:

JANUARY 2023

Page:

100240

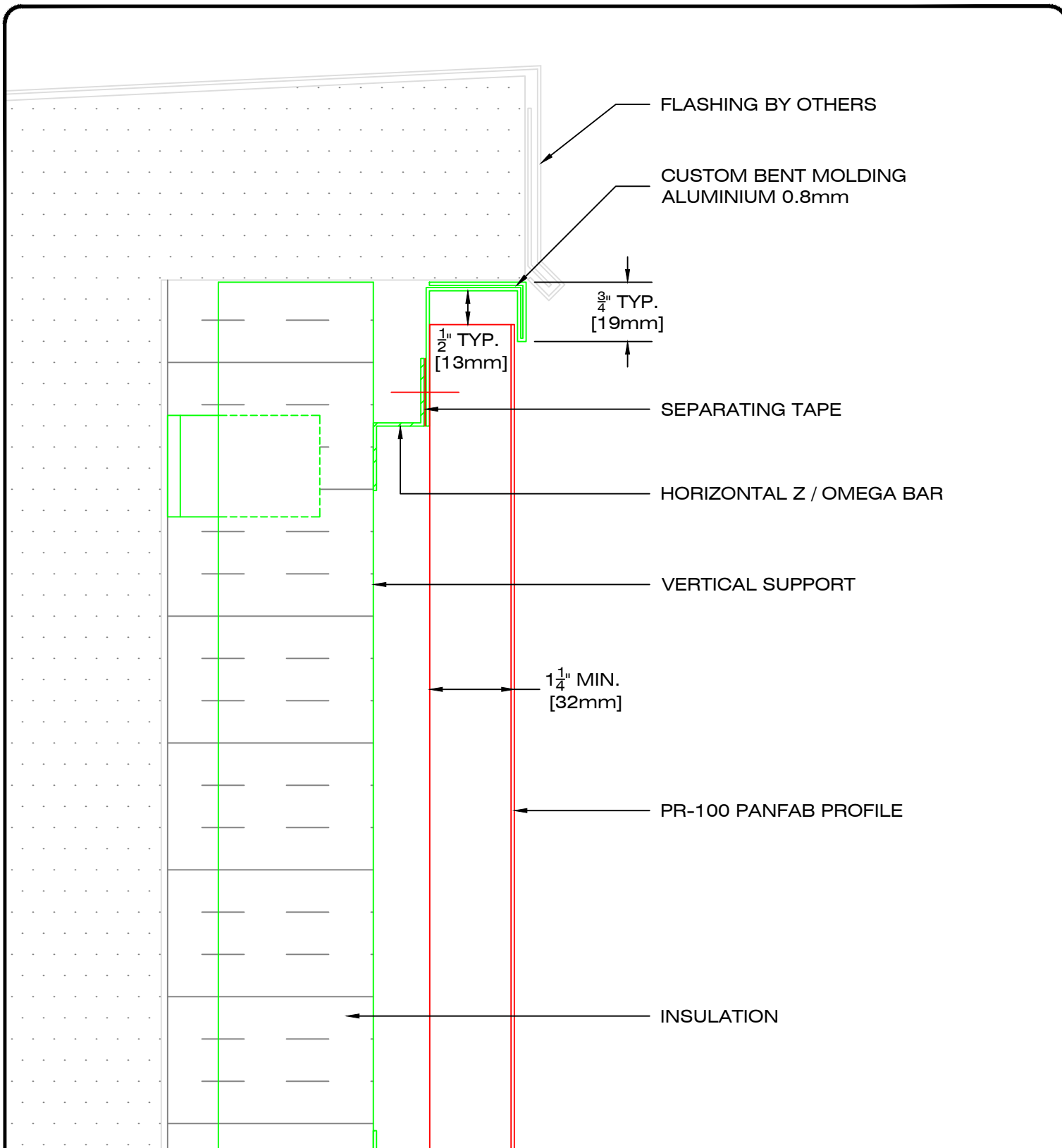

LES INDUSTRIES



49, boul. de la Seigneurie Est
Blainville (Québec) J7C 4G6

Phone : (450) 430-3029

www.panfab.com

Project:

PR-100 PANFAB PROFILE

Title:

SECTION - PARAPET

Scale:

1:2

Date:

JANUARY 2023

Page:

100250

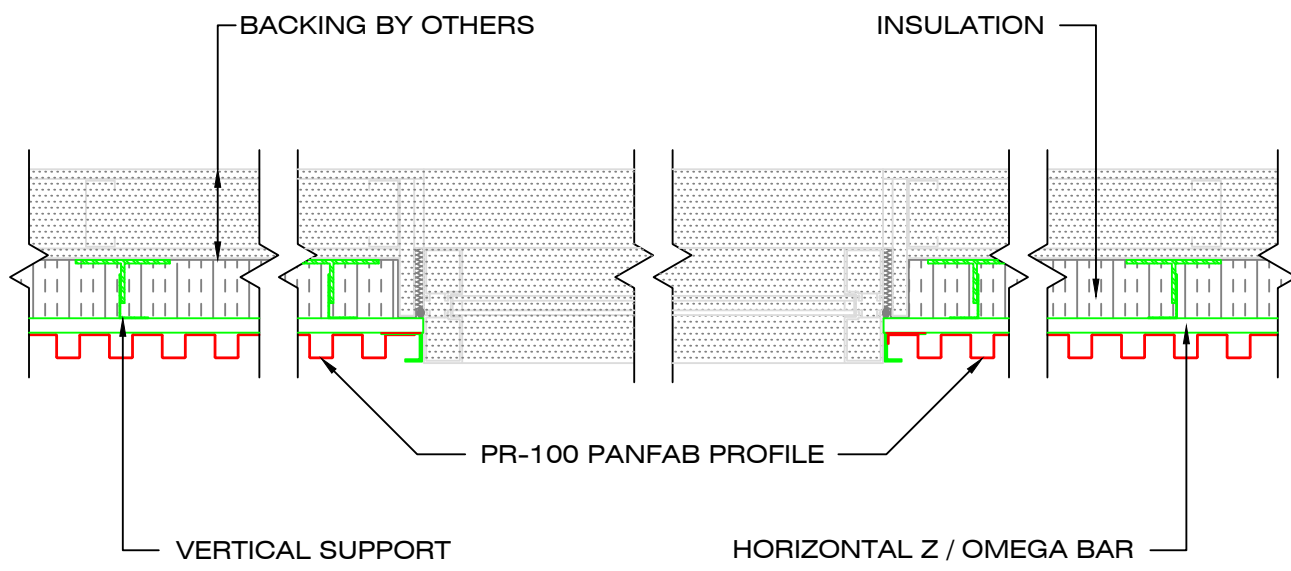

LES INDUSTRIES



49, boul. de la Seigneurie Est
Blainville (Québec) J7C 4G6

Phone : (450) 430-3029

www.panfab.com

Project:

PR-100 PANFAB PROFILE

Title:

PLAN VIEW

Scale:

1:10

Date:

JANUARY 2023

Page:

100300

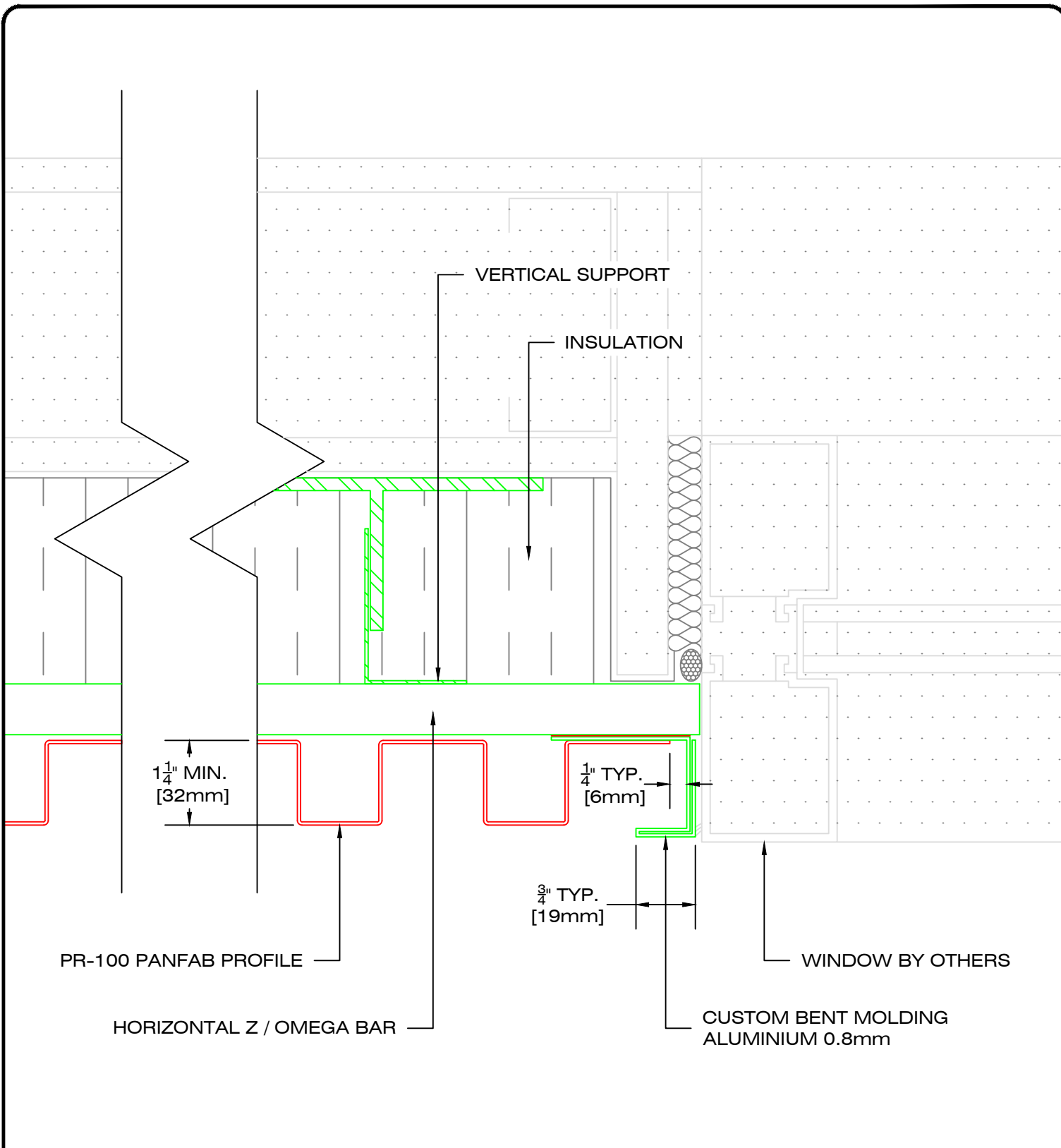

LES INDUSTRIES



49, boul. de la Seigneurie Est
Blainville (Québec) J7C 4G6

Phone : (450) 430-3029

www.panfab.com

Project:

PR-100 PANFAB PROFILE

Title:

PLAN VIEW - VERTICAL WINDOW FLASHING

Scale:

1:2

Date:

JANUARY 2023

Page:

100310

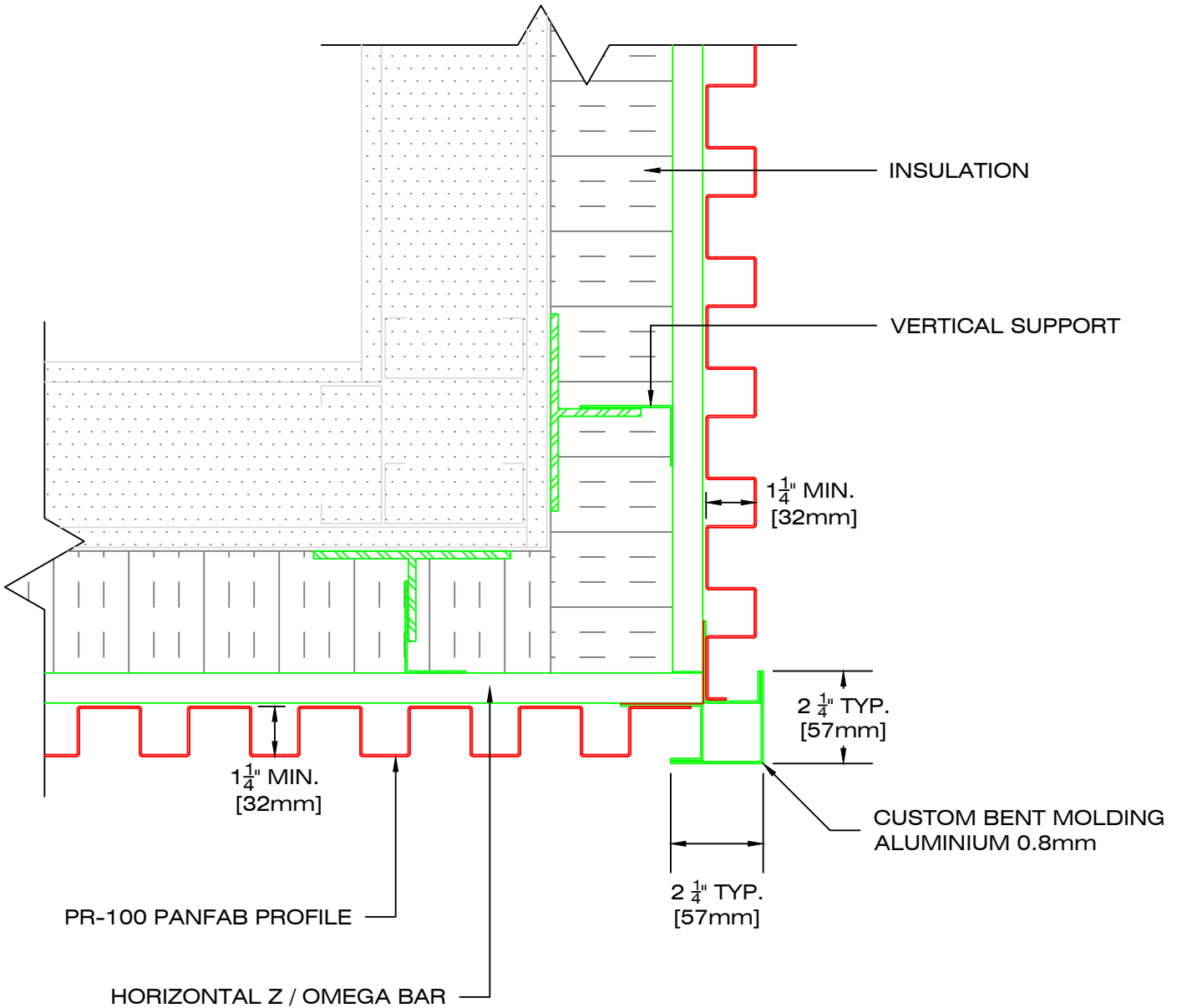

LES INDUSTRIES



49, boul. de la Seigneurie Est
Blainville (Québec) J7C 4G6

Phone : (450) 430-3029

www.panfab.com

Project:

PR-100 PANFAB PROFILE

Title:

PLAN VIEW - OUTSIDE CORNER

Scale:

1:4

Date:

JANUARY 2023

Page:

100320

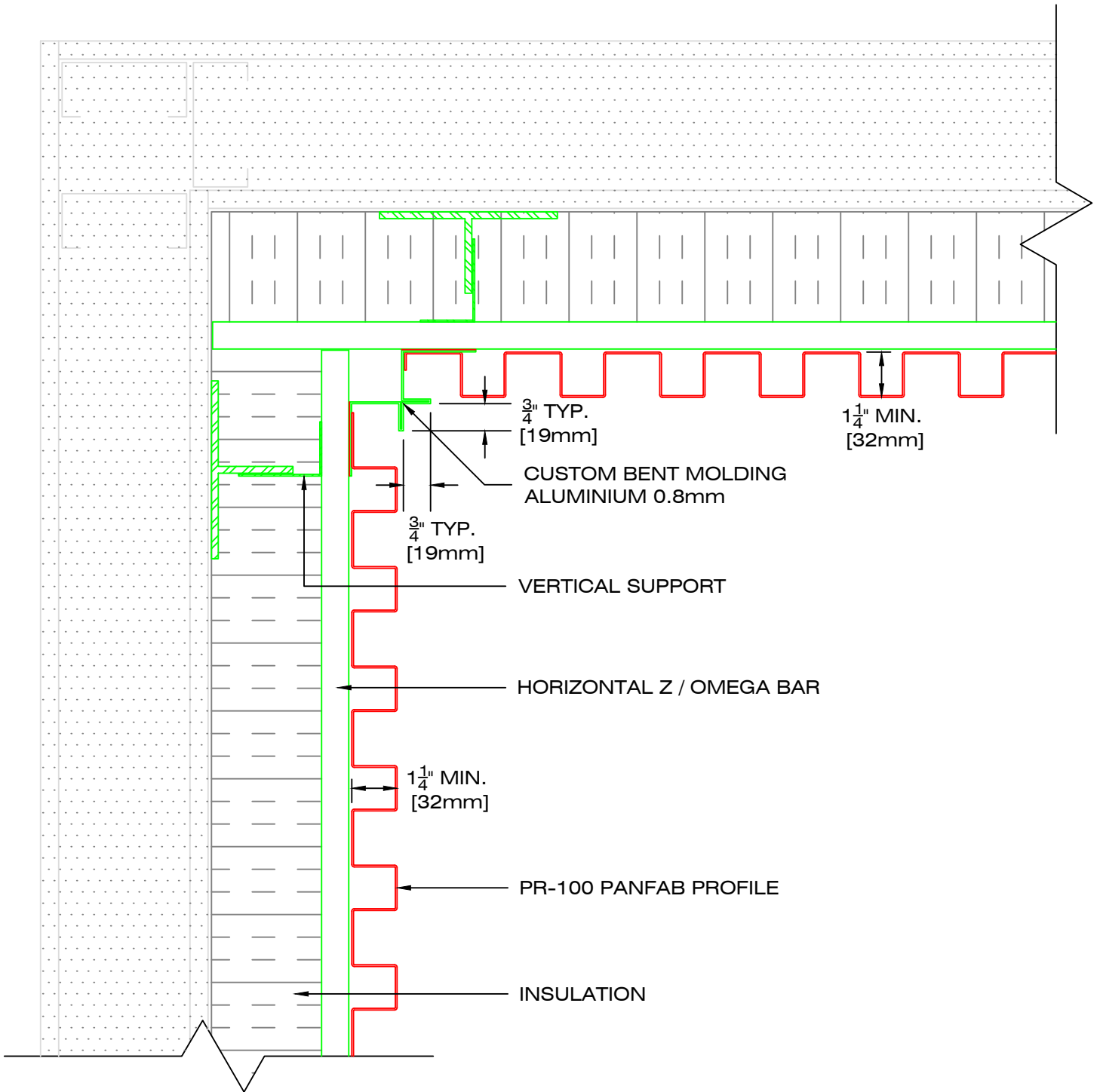

LES INDUSTRIES



49, boul. de la Seigneurie Est
Blainville (Québec) J7C 4G6

Phone : (450) 430-3029

www.panfab.com

Project:

PR-100 PANFAB PROFILE

Title:

PLAN VIEW - INSIDE CORNER

Scale:

1:4

Date:

JANUARY 2023

Page:

100330

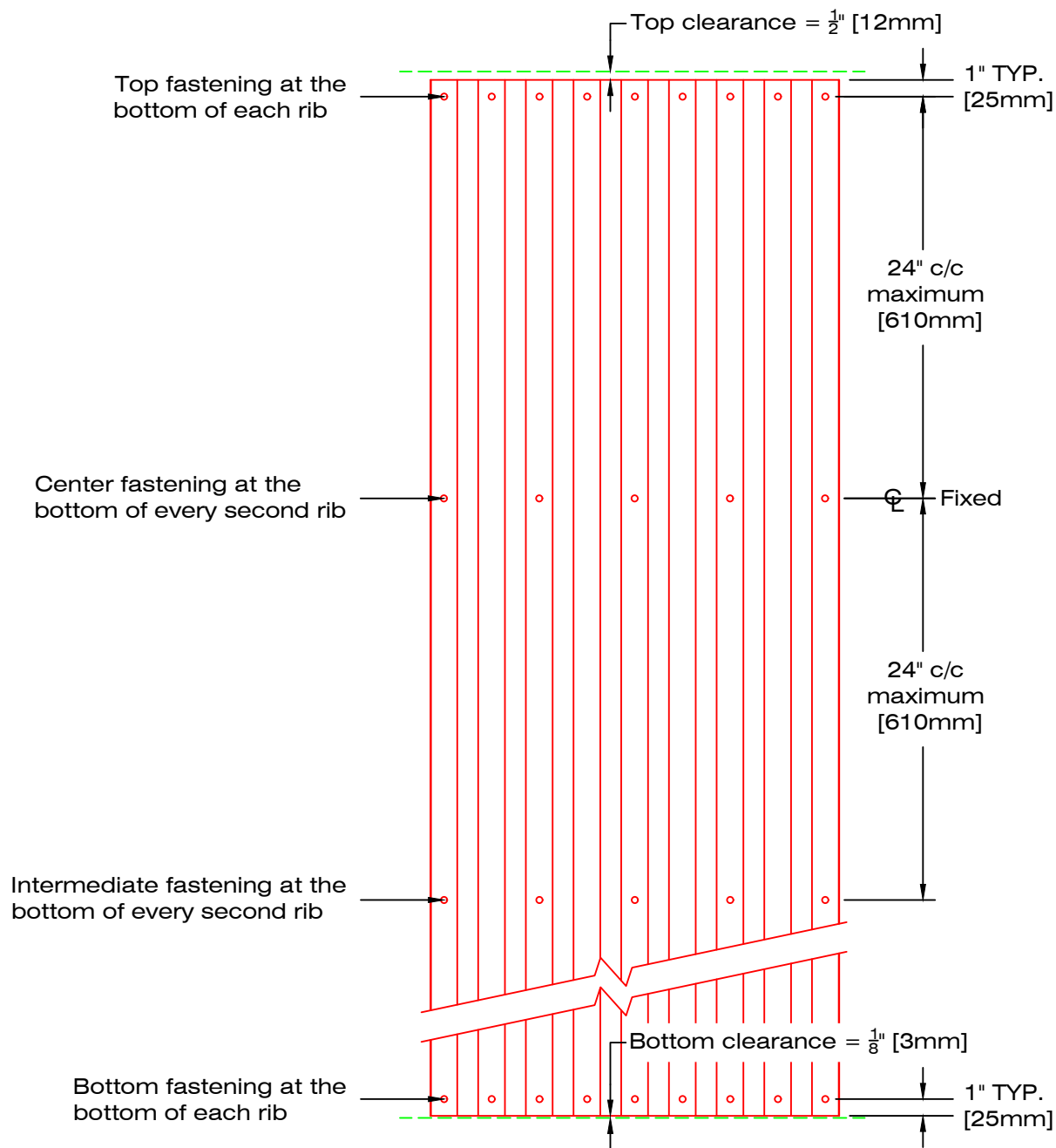

MODEL PR-111

VISIBLE FASTENERS AT THE BOTTOM OF THE RIB

Suggested fastener: 12-14 1" screws, 410 stainless steel, type SD3, bondseal, hexagonal head, sealing washer
 (Note: fastening and spacing to be validated by an engineer according to models and project conditions)

LES INDUSTRIES



49, boul. de la Seigneurie Est
Blainville (Québec) J7C 4G6

Phone : (450) 430-3029

www.panfab.com

Project:		PR-100 PANFAB PROFILE
Title:		FASTENING INSTALLATION
Scale:	1:10	Page: 100400
Date:	JANUARY 2023	